

星锐牌工业用缝纫机

SHING RAY BRAND INDUSTRIAL SEWING MACHINE

使用说明 & 维修手册

Instruction & Maintenance Book

FW-760



星锐缝纫机(嘉兴)有限公司

★ SHING RAY®

SHING RAY SEWING MACHINE(JIAXING) CO., LTD.

一、安全上的注意事项

- 1-1 作业环境的安全
- 1-2 安装的安全
- 1-3 操作中的安全
- 1-4 保养维修的安全
- 1-5 危险标志, 请注意标示

二、使用说明

- A 安装
- B 润滑
- C 润滑油之更换
- D 滤油器之更换
- E 针之更换
- F 穿线方式
- G 押脚压力强度之调整

三、调整说明

- A 针棒高度之调整
- B 针与勾针之时位关系
- C 下勾针与针之引量
- D 勾针与针之间隙关系
- E 针与后护针片调整
- F 针与前护针片调整
- G 针与上勾针及线导片之关系
- H 送步齿高度调整
- I 勾针控线凸轮之调整
- J 差动比调整

四、自动切线调整说明

- A 下切刀组相关位置调整
- B 下切刀组切线之相关位置
- C 下切刀组与针线及下勾针线之关系
- D 上切刀组与上饰线、针及勾针之关系
- E 拨线器相关位置调整

五、简易故障排除

- A 清洁保养
- B 故障(用户)自主检查
- C 调整基准数值表
- D 针距规格表
- F 结论

SAFETY PRECAUTION

- 1-1 WORK ENVIRONMENT 1
- 1-2 SAFETY IN INSTALLATION 2
- 1-3 SAFETY IN OPERATING 3
- 1-4 SAFETY IN MAINTENANCE AND REPAIRS 3
- 1-5 DANGER AND CAUTION SIGNS 4

OPERATION GUIDE

- A INSTALLATION 5
- B LUBRICATION OIL 6
- C OIL CHANGE 7
- D REPLACING OIL FILTER 7
- E HOW TO REPLACE THE NEEDLES 8
- F THREADING 8
- G ADJUSTING THE PRESSURE OF PRESSER FOOT 9

ADJUSTMENT GUIDE

- A THE HEIGHT OF NEEDLE BAR 10
- B TIMING OF NEEDLE AND LOOPER 11
- C THE POSITION OF NEEDLE AND LOOPER 12
- D THE TIMING OF NEEDLE AND LOOPER 13
- E ADJUSTING NEEDLE AND REAR NEEDLE GUARD 14
- F ADJUSTING NEEDLE AND FRONT NEEDLE GUARD 15
- G THE RELATIVE POSITION OF NEEDLE、SPREADER AND SPREADER THREAD GUIDE 16
- H ADJUSTING THE HEIGHT OF FEED DOG 17
- I THE ADJUSTMENT OF LOOPER THREAD TAKE-UP 17
- J ADJUSTING THE DIFFERENTIAL FEED RATIO 18

AUTO THREAD TRIMMER ADJUSTMENT GUIDE

- A THE RELATIVE POSITION ADJUSTMENT OF BOTTOM TRIMMER CUTTING PARTS TRIMMER CUTTING PARTS 19
- B THE RELATIVE POSITION ADJUSTMENT OF BOTTOM TRIMMER 21
- C THE RELATIVE POSITION OF NEEDLE、LOOPER THREAD AND BOTTOM TRIMMER 23
- D THE RELATIVE POSITION OF SPREADER THREAD、NEEDLE、SPREADER AND TOP TRIMMER 24
- E THE RELATIVE POSITION OF TOP WIPER 26

REGULAR MAINTENANCE

- A THE CLEAR AND MAINTENANCE 27
- B ERROR MESSAGES (THE USER INSPECTS THE MACHINE BY THEMSELVES) 28
- C TABLE OF ADJUSTMENT STANDARD VALUES 33
- D STITCH OF NEEDLES SPECIFICATION 34
- F CONCLUSION 34



SHING RAY®

安全上的注意事项

使用本机前请仔细阅读本说明书及所搭配之马达说明书，配合正确使用，并须由受过正确训练之人员来安装或操作。微型伺服马达为本机专用，在安装和操作时，必须做好以下预防措施。

1-1 作业环境的安全：

(1) 电源电压：

电源电压请遵照马达与 i60 控制箱铭牌所标示之规格 $\pm 10\%$ 范围内操作。

(2) 电磁波干扰：

请远离高周磁波器或电波发射器等，以免产生的电磁波干扰本驱装置，因而发生错误动作。

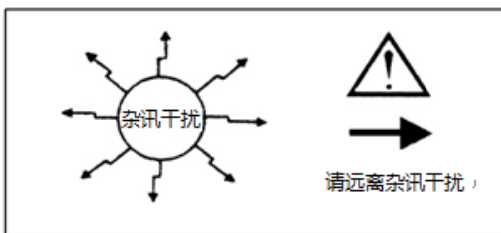

(3) 温湿度：

1. 请不要在室温 45°C 以上或 5°C 以下的场所操作。
2. 请不要在日光直射的场所或室外运作。
3. 请不要在暖气(电热器)旁运作。
4. 请不要在相对湿度 30% 以下或 95% 以上或有漏水的场所运作。

SAFETY PRECAUTION

Please read this manual carefully, also with related manual for the machine head before use. For perfect operation and safety, installing and operating this product by trained personal is required. When install and operate HVP-70 MINI SERVO MOTOR, precaution must be taken as the following. This product is designed for specify sewing machine and must not be used for other purposes.

1.1 Work Environment:

(1) Power voltage:

Only use Power Voltage indicated on the name plate of the i60 in $\pm 10\%$ ranges

(2) Electromagnetic pulse interference:

To avoid the false operate, please keep the product away from the high electromagnetic machinery or electro generator

(3) Temperature:

- a. Please don't operate in room temperature is above 45°C or under 5°C
- b. Avoid operating in direct sun light or outdoors area.
- c. Avoid operating near the heater.
- d. Avoid operating in the area which humidity is 30% or less and 95% or more, also stay away from dew area.



SHING RAY®

(4) 环境:

1. 请不要在尘土飞扬的区域操作, 并远离腐蚀性物质。
2. 请不要在有易蒸发或者有可燃气体的区域动作。

1-2 安装的安全:

(1) 机器、马达、控制箱, 请遵照说明书正确装好。

(2) 电源线:

1. 请注意不要被重物压或过度扭曲电源线
2. 装钉电源线时请不要靠近会转的手轮、皮带轮及三角皮带, 最少要离开 3~5 公分以上。
3. 接线前须检查插座电源电压, 确保其与 i60 电控箱所标示 $\pm 10\%$ 的电压相匹配

(3) 接地:

1. 为防止噪声干扰或漏电事故, 请做好接地工程。
2. 电源线的接地线须以适当大小的导线和接头连接到生产工厂的系统地线, 此连接必须被永久固定。

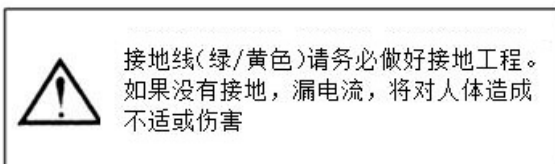
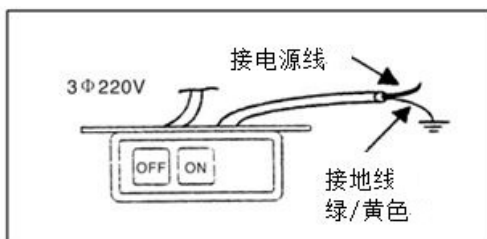

(4) Atmosphere:

- a. Avoid operating in dusty area, and stay away from corrosive material.
- b. Avoid operating in evaporate or combustible gas area.

1.2 Safety In Installation:

(1) Machine, motor and control box, follow the instruction in this manual for correct installation.

(2) Power cord:

- a. Avoid power cord being applied by heavy objects of excessive force, or over bend
- b. Power cord must not set to be near the handwheel, keep 3cm spare or above.
- c. Check the outlets voltage before plugging the cord, make sure it match the voltage shown on the name plate of the i60 in $\pm 10\%$ ranges.

(3) Grounding:

- a. To avoid the static interference and current leakage, all grounding must done.
- b. Use the correct connector and extension wire when connecting ground wire to Earth and secure it tightly.



SHING RAY®

1-3 操作中的安全:

- (1) 在第一次开电后, 请先以低速操作缝纫机, 并检查转动方向是否正确。
- (2) 缝纫机运转时请不要去触摸手轮、天秤、针等会动作的部位。
- (3) 请不要在拆下皮带护盖及其它安全装置的情形下操作。
- (4) 操作缝纫机时, 针棒前方之透明护目板, 必须移到针镙前方之正常位置。

1-4 保养维修的安全:

在以下操作前, 请先关闭电源:

- (1) 要拆卸马达或控制箱时, 或在控制箱上插或拔任何连接插头时。
- (2) 控制箱里面有危险高压电, 所以关闭电源后要等 10 分钟以上, 方可打开控制箱外盖。

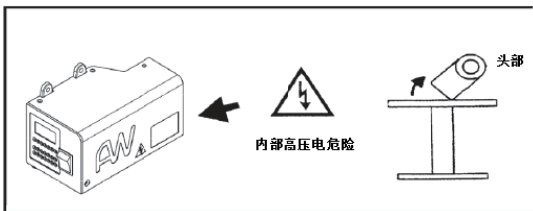

- (3) 翻抬车头时, 与更换机针或穿线时(上图所示)。
- (4) 机械上的修理及调整时。
- (5) 机械休息不用时。

1.3 Safety In Operating:

- (1) When turn on the machine in the first time, use low speed to operate and check the correct rotation direction.
- (2) During machine operation, don't touch any moving parts.
- (3) Please don't operate the machine under to take out the Belt Cover and another safety advice
- (4) When you operate the sewing machine, the "Eye Guide" must be moved to the correctly position which in the front of needle holder.

1.4 Safety in Maintenance and Repairs:

Power must be turned off first, when:



- (1) Uninstall the motor to the control box., or plug and unplug any connector.
- (2) Turn off the power and wait 10 minutes before opening box cover.

- (3) Raising the machine arms or changing needle, or threading needle. (show as above)
- (4) Repairing or doing any mechanical adjustment.
- (5) Machines rest



SHING RAY®

1-5 危险标志，请注意标示：

- (1)  这两个标志符号表示机器安装时，如有错误会伤害到人体或机器会受到损坏，所以机器方面有危险性的地方会有此标示。
- (2)  这个标志符号表示有高压电等电气方面有危险的地方会有此标示。

1.5 Danger and Caution Signs:

- (1) Risks that may cause personal injury or risk to the machine are Marked with this symbol in the instruction manual.
- (2) This symbol indicate electrical risks and warnings



SHING RAY®

使用说明

A 安装:

1. 请依本机配件盒内零件图所附之正确桌板尺寸图裁制桌板。
2. 桌板厚度约 45mm。
3. 直驱微型小马达之机头与桌板之安装固定方式, 请参照(图 1)之安装注意事项 1、2 点。
4. 直驱微型小马达机器之桌板、脚架、计算机控制箱及其他相关配件之安装位置示意图, 请参考(图 2)。

温馨提示:

出于安全考虑, 所有用户请务必安装好接地线以防静电。

OPERATION GUIDE

A. INSTALLATION:

1. Before installing machine, please refer to Table Drawing. To cut the table out in correctly.
2. The table thickness is 45mm.
3. Please refer to (Fig.1) and the Remark 1 & 2 for installing the “Directly Driving Type Mini-Servo Motor” machine head and table.
4. Please refer to the Installation Schematic Drawing (Fig. 2) for installing the “Directly Driving Type Mini-Servo Motor” machine head, foot stand, control box and accessories.

Remark:

For security reason, We are warning all of users that please always install the grounding wire to avoid the Static Electricity.

微型小马达之机头与桌板安装方式

(一) 桌板正面图

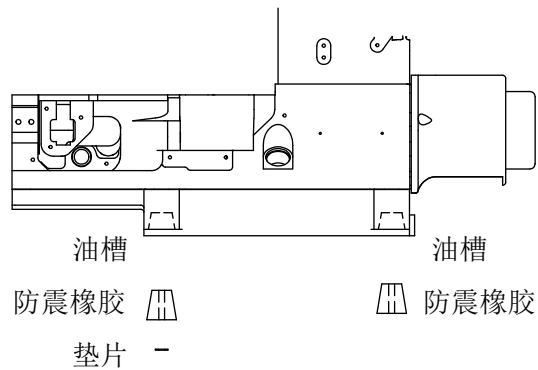
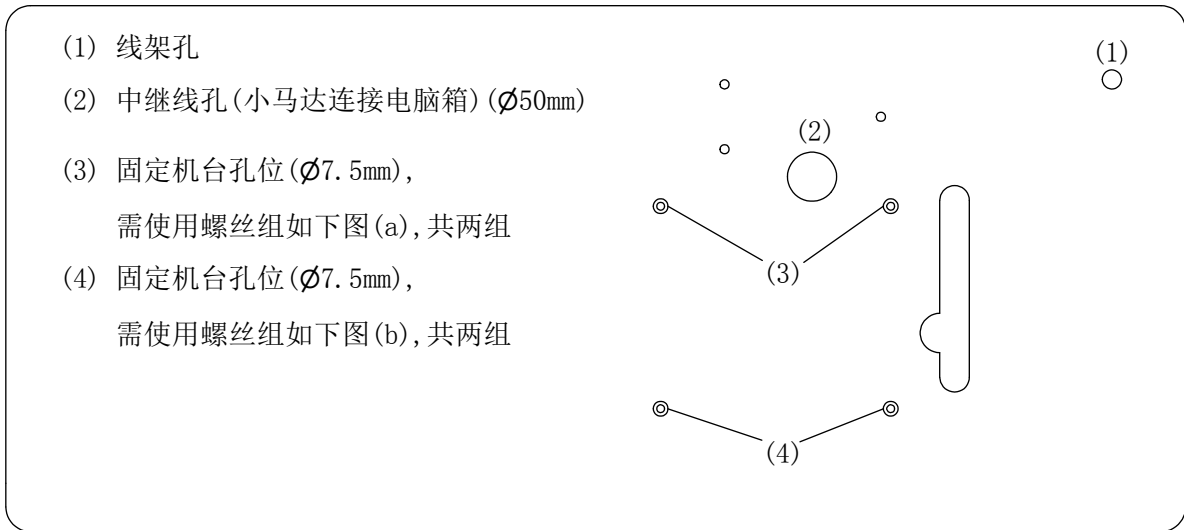

(二) 桌板分解图

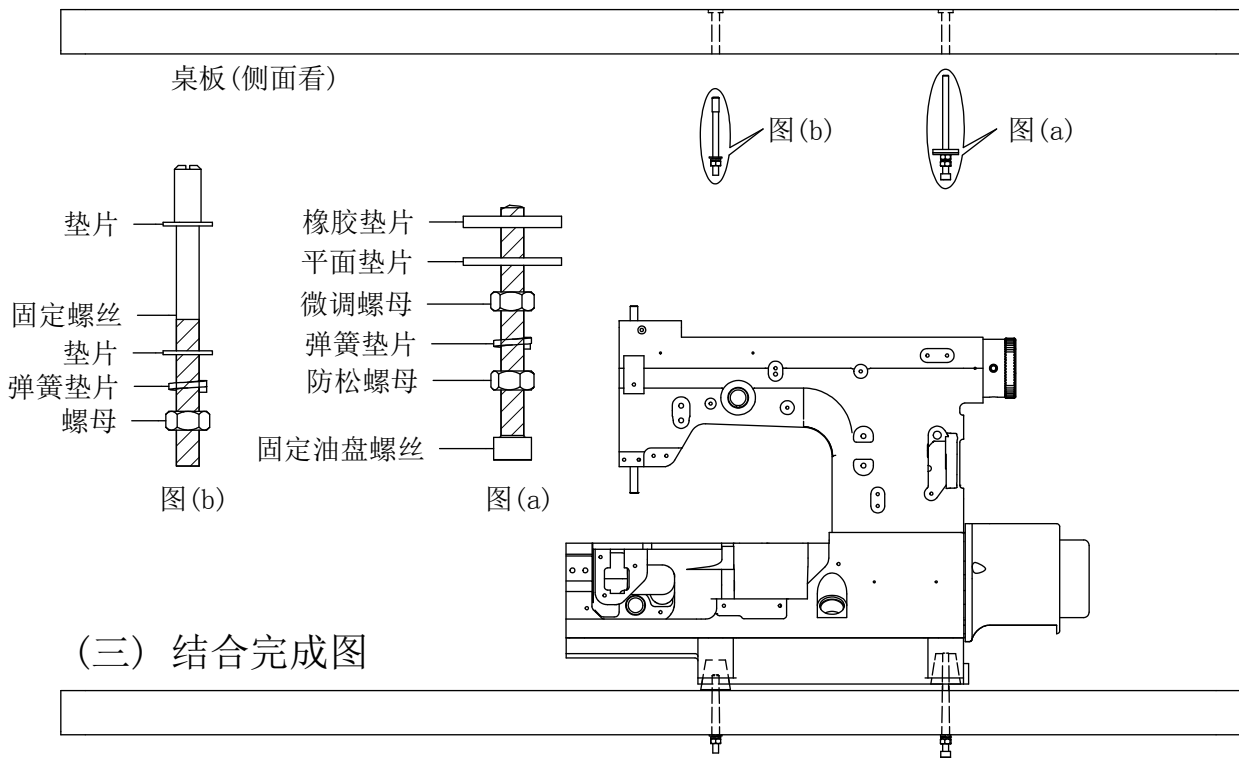

(三) 结合完成图

- 安装注意事项 :
1. 先将固定螺丝往上旋转至顶点, 在用微调螺母往上旋转至平面垫片, 接触到橡胶垫片, (此时橡胶垫片处于被轻微夹住, 平面垫片尚可旋转状态)防松螺母在锁紧微调螺母即可。
 2. 请注意4颗固定螺丝(或微调螺母), 紧度须平均以防桌板共振产生异音

Fig. 1

The Installation of Mini-Servo Motor Machine Head and Table

(一) The Table Front View

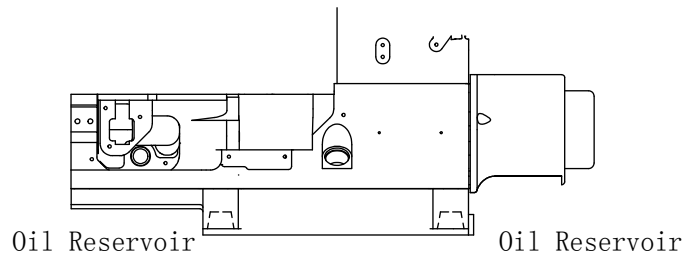
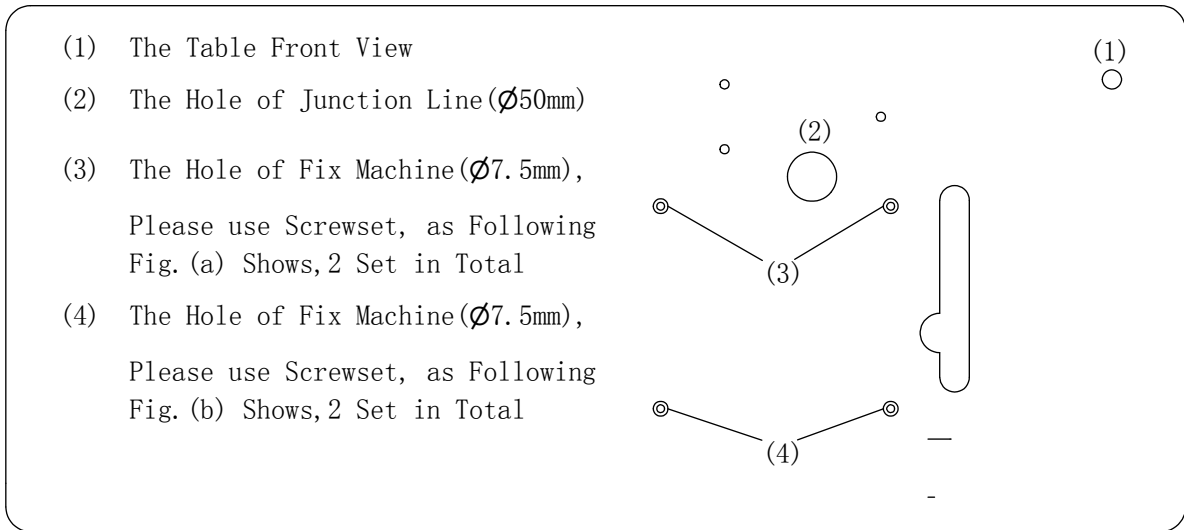

(二) The Separate

Drawing of Machine

Rubber Cushion
Waster -

Rubber Cushion

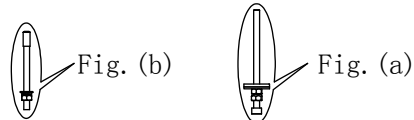
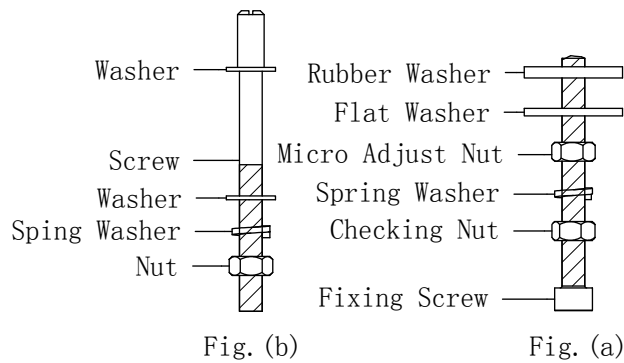

(三) The Finish Drawing

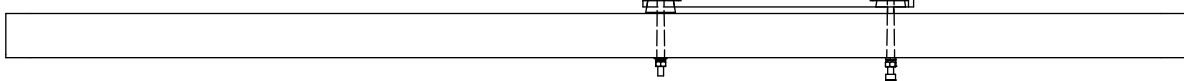

Remark :1. Plesae turn the Fixing Screw to the top, Then, the Micro Adjust Nut turn to the Flat Washer ang touch the Rubber Washer, (During the time, The Rubber Washer has been clipped in lightly. The Flat Washer still could move) Finally, The Checking Nut lock to The Micro Adjust Nut.

2. The 4 Fixing Screws (or, Micro Adjust Nut) must be fixed the machine head in even which to avoid the noise of Table Resonance.

FW-760T(N) 系列产品与下沉式桌板安装方式

(一) 各部位置说明:

- (1) 线架孔
- (3) 托架固定孔x4孔, 需使用螺丝如下图(e), 共四组
- (5) 固定机台孔位($\varnothing 13\text{mm}$),
需使用螺丝组如下图(d), 共四组

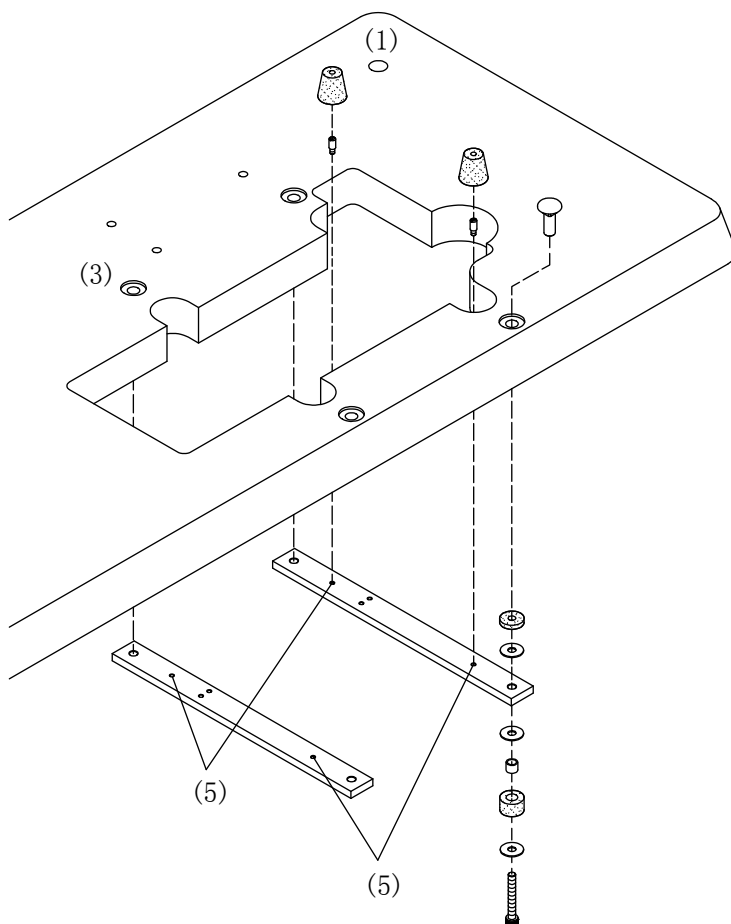
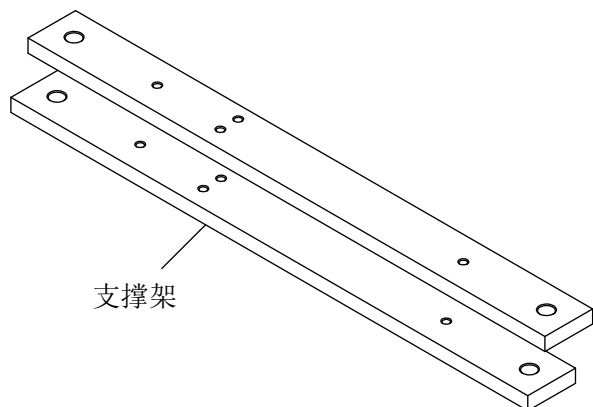

(二) 螺丝组装说明:

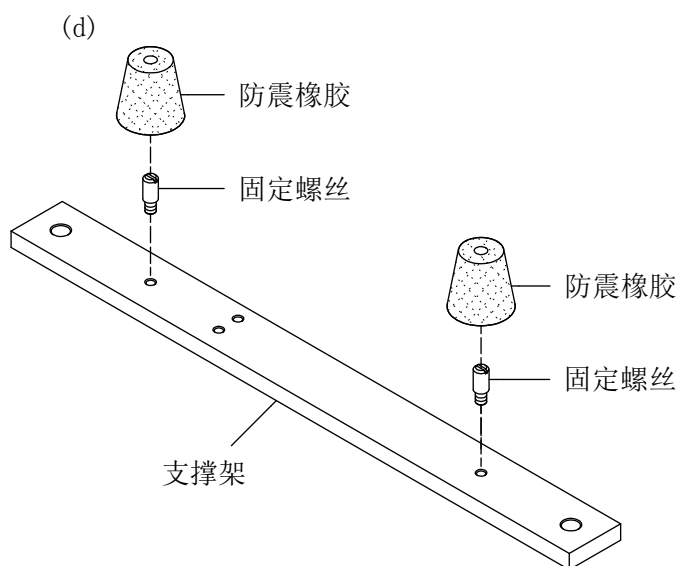
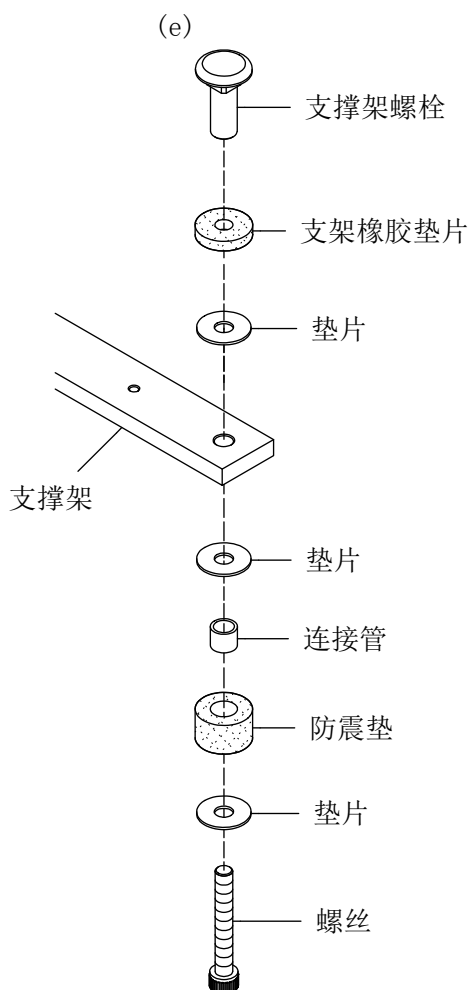
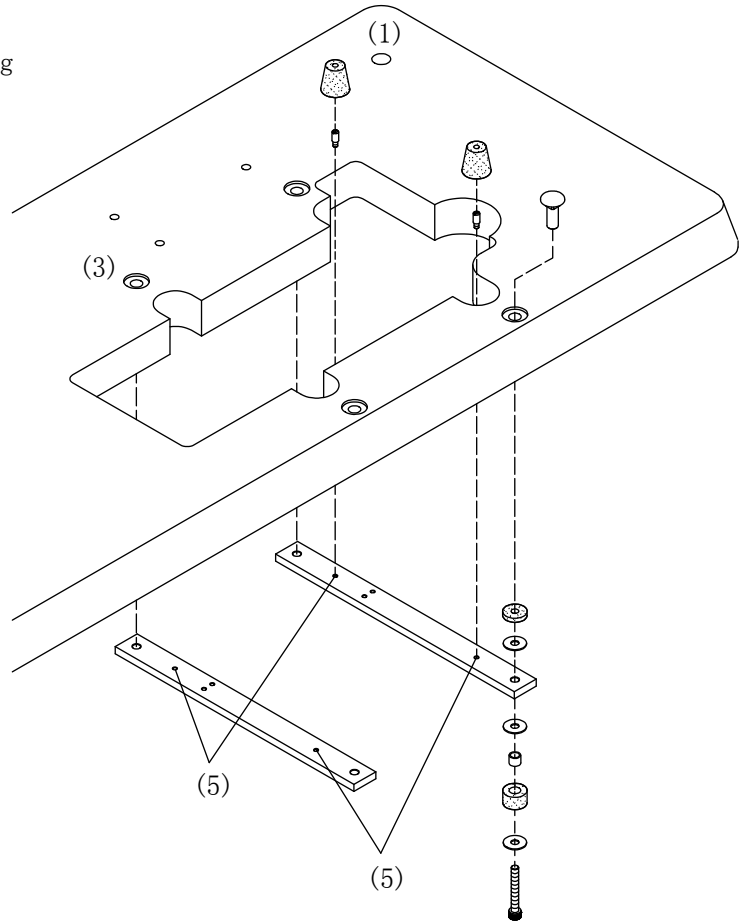
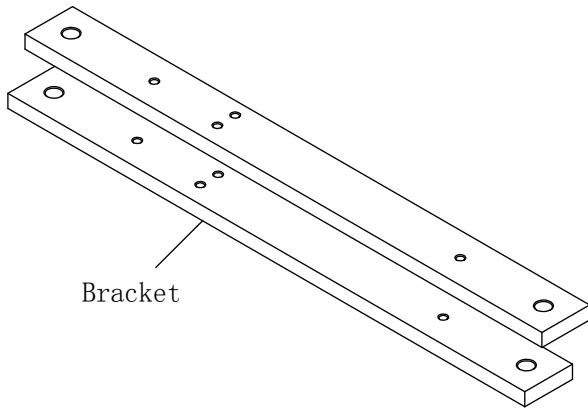

Fig. 2

FW-760T(N) Series Products and installation of sinking table

(一) Location description of each part:

- (1) The Hole of Thread Stand
- (3) The Hole of Bracket fixing x 4 holes,
Please Use Screw set, as following
Fig. (e) Shows, 4 Set in Total
- (5) The Hole of fix Machine($\varnothing 13\text{mm}$),
Please Use Screw set ,as following
Fig. (d) Shows, 4 Set in Total



(二) Screw Assembly Instructions:

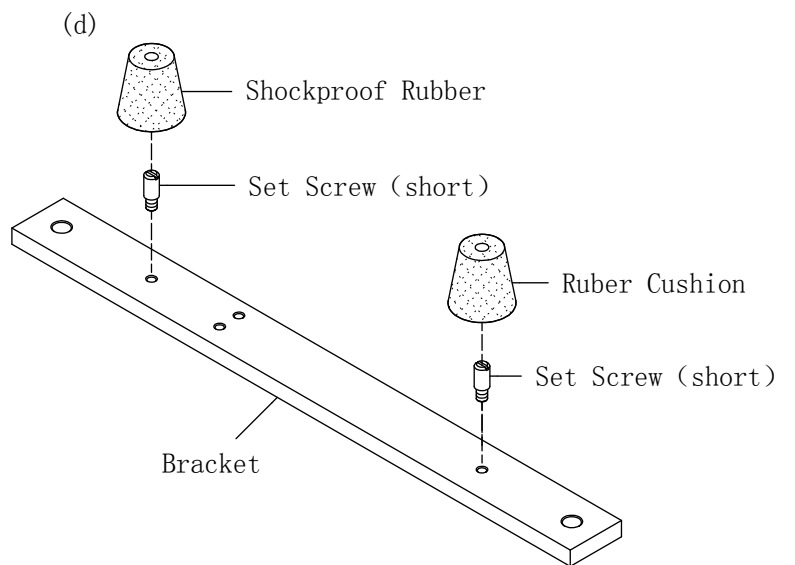
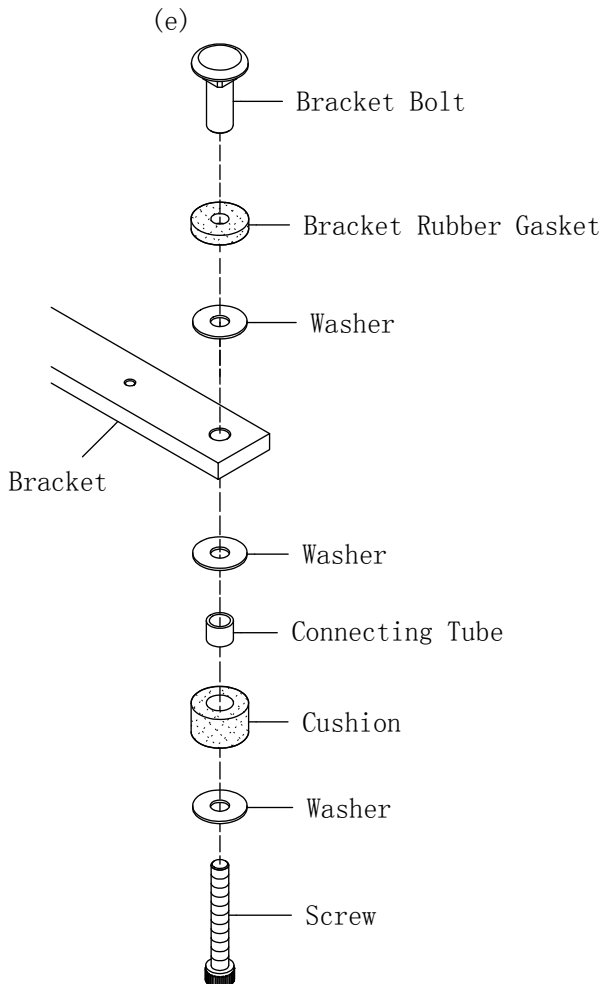



SHING RAY®

B 润滑:

1. 请选用与 PMOBIL#10 同级之润滑油。
2. 在新机使用前请先注入润滑油。旋开顶盖上的喷油检视盖(A)，将油缓缓注入机器中，待油量满至油标指示窗(B)上下线之间即可(图3)。
3. 于每天开机操作时，请先检查喷油状态是否正常，且注意油量是否低于指示窗之下限，若低于下限请随时补充新油。

B. LUBRICATION OIL:

1. Please use MOBIL #10 or it's equivalent.
2. Before operating the new machine, to remove Oil Sight Window (A) and fill the oil slowly until the oil level reaches between lines H and L of Oil Sight Gauge (B). (Fig. 3)
3. When you begin operating the machine in everyday, please check whether all the lubricating systems at normal condition. If oil level is lower than L of Oil Sight Gauge, please refill oil.

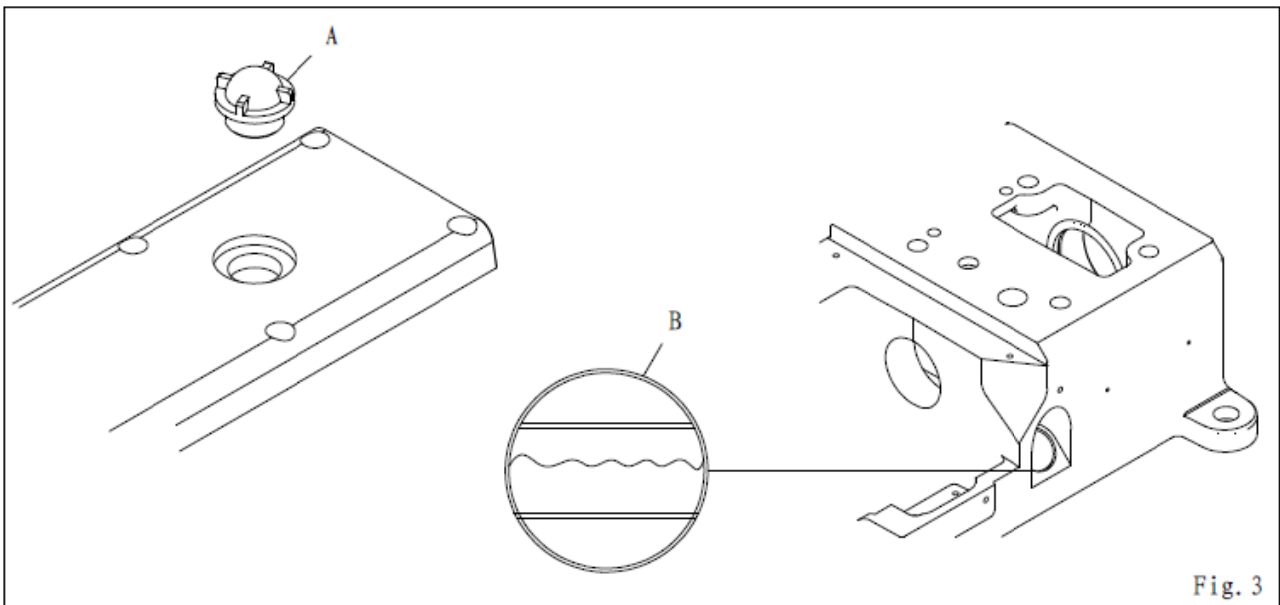



SHING RAY®

C 润滑油之更换:

1. 将放油螺丝 (A) 松开, 使油槽内的旧油完全排出后, 再将放油螺丝锁紧 (图 4) 在依 B-2 的步骤注入新油。
2. 为延长本机的使用寿命, 请于开始使用的一个月内更换第一次新油, 往后约每 6 个月更换一次。

D 滤油器之更换:

本机装有滤油器, 新机使用一个月后更换新品。此后仅需每 6 个月更换一次。(图 5)

C. OIL CHANGE:

1. Remove screw (A) and drain all the oil from the tank. After draining, tighten screw (A) without fail. Please refer to B-2 for replenishing new oil. (Fig. 4)
2. For the long life of machine, please change lubrication oil completely after one month of initial operation. After first time, to change lubrication oil every six months per time.

D. REPLACING OIL FILTER:

This machine is equipped with an Oil Filter, to change the Oil Filter after one month of initial operation. After that please change Oil Filter every six months. (Fig. 5)

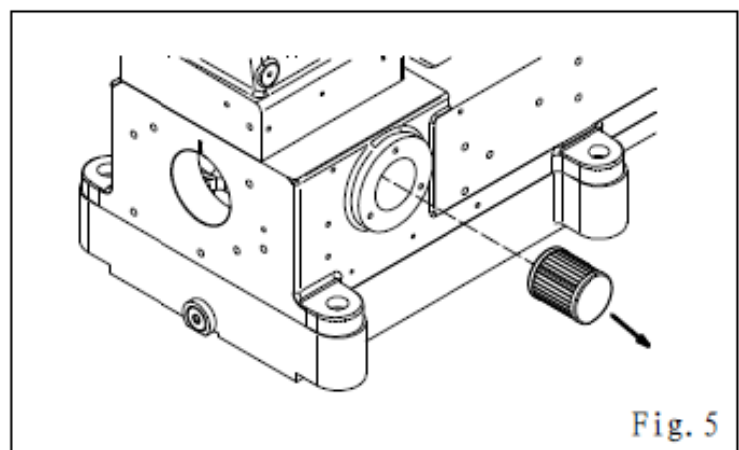
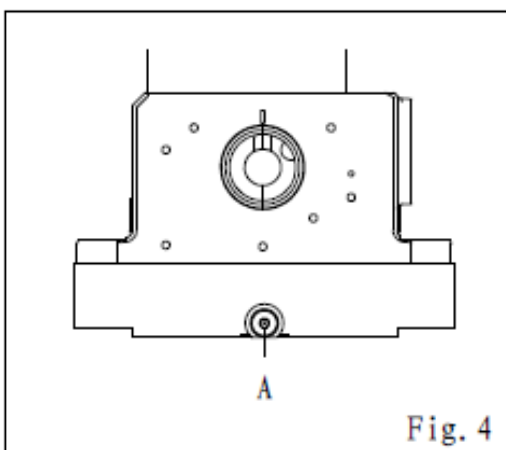



SHING RAY®

E 针之更换:

1. 请选用 UY128GAS, 10 番的针或其他相同规格之针。
2. 旋开锁针螺丝(A), 并取下旧针, 将新针插至针座之最顶端, 且使长沟面向自己。(图 6)
3. 重新将锁针螺丝锁紧(A)。

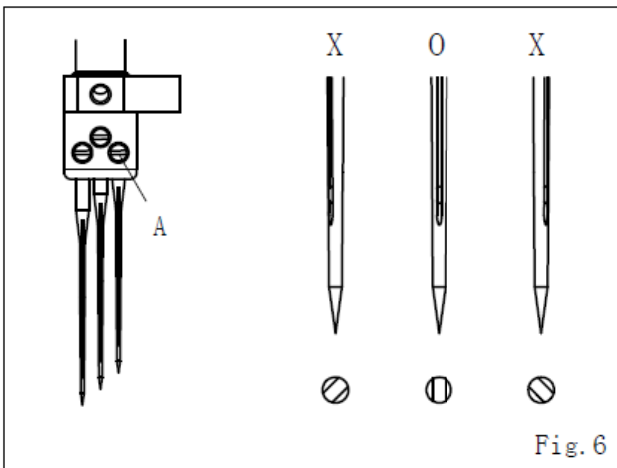

F 穿线方式:

请按照图中所指示的穿线方式正确穿线, 若穿线方式错误, 将会引起断线、跳针或车缝不平坦等现象。(图 7)

E. HOW TO REPLACE THE NEEDLES:

1. Please use UY128GAS #10 of Organ's needle or it's equivalent.
2. Loosen screw (A), then, pull out the used needles. Insert the new needles into the holder holes as far as they can go, and let the long groove of the needle face you. (Fig. 6)
3. Fasten screw (A).

F. THREADING:

Threading should be made correctly. Refer to the illustration. (Fig. 7) The wrong threading may cause thread breaking, skipping stitch or puckering.



SHING RAY®

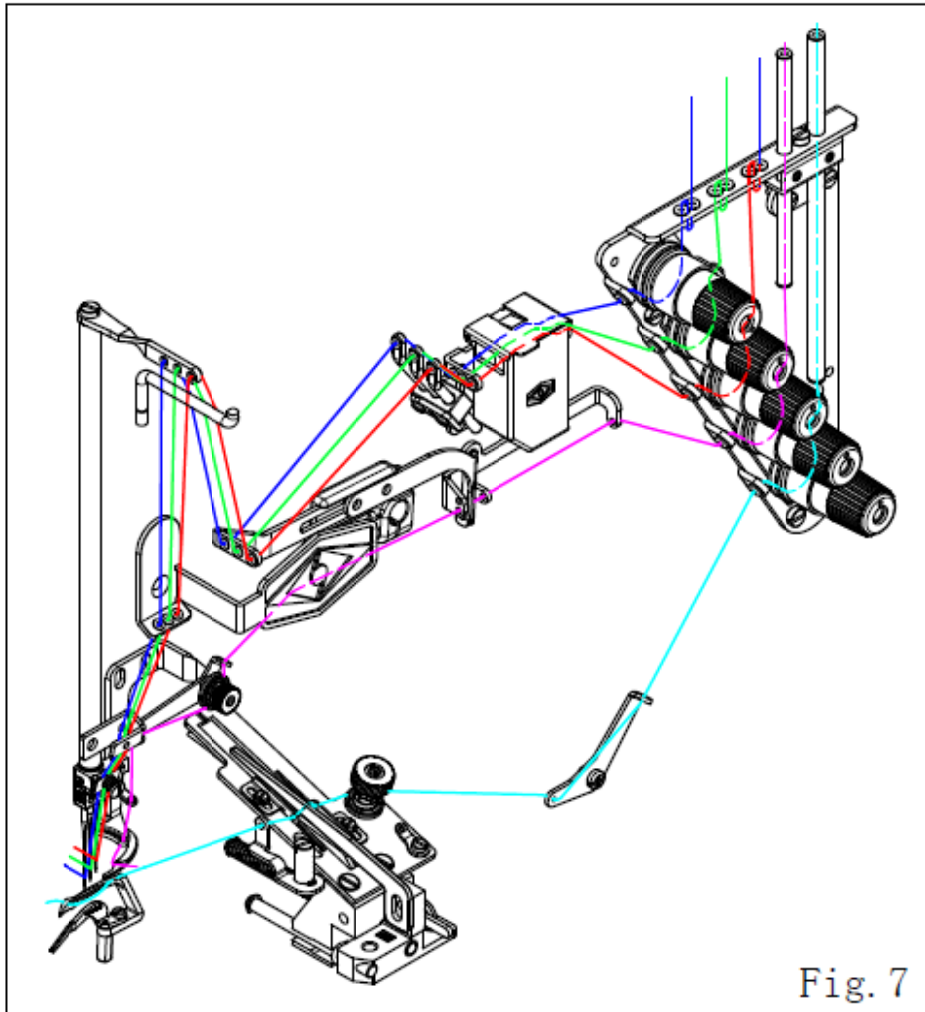

Fig. 7

G 压脚压力强度之调整:

1. 若要求布料推送顺畅且缝合完美，压脚压力应尽量轻些。
2. 松开螺母(A)，转动螺丝(B)，调整其适当压力后再锁紧螺母(A)。(图8)

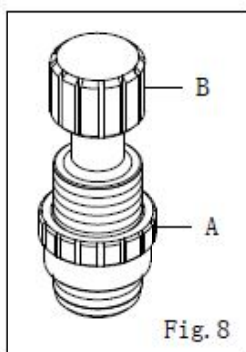

Fig. 8

G. ADJUSTING THE PRESSURE OF PRESSER FOOT:

1. Pressure of Presser Foot should be as weak as possible, so that cloth can be sewed and fed smoothly.
2. To increase the pressure of Presser Foot, to turn Adjusting Screw (B) clockwise after loosening Lock Nut (A) and to decrease the pressure turn Screw (B) counterclockwise. (Fig. 8)



SHING RAY®

调整说明

A 针棒高度之调整:

1. 先将针棒升到最高处，此时最长针的针尖与针板的距离为 8.2~8.5mm。(图 9)
2. 若需要调整时，请先打开机头前盖之止油胶盖(A)，放松针棒连杆上的螺丝(B)，上下调整针棒的高度后再固定之。(图 10)

注意:

- (1) 针必须完全装入针镗孔最顶端。
- (2) 经过针棒高度调整后，必须确定每一根针皆通过针板的针孔正中央，不可以偏斜，且三根针需呈平行。(图 11)

ADJUSTMENT GUIDE

A. THE HEIGHT OF NEEDLE BAR:

1. Please lift the Needle Bar to the highest position. During this time, the standard height between the longest right needle point and Needle Plate are 8.2~8.5 mm. (Fig. 9)
2. If you would like to adjust the height of Needle Bar, please remove the rubber plug of front cover and loose the screw (B) on Needle Bar Rod (A). Adjust the Needle Bar up or down to require height and fix the screw. (Fig. 10)

Remarks:

- (1) Be sure insert the needle into the Needle Holder as far as it can go.
- (2) After the Needle Bar adjustment, please make sure that every needle are passed though the center of the needle hole on the Needle Plate. Beside, the three needles must be in parallel and the gap must be even. (Fig. 11)

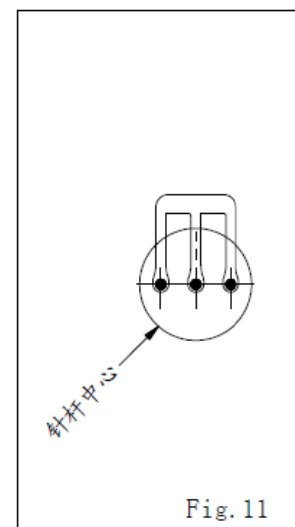
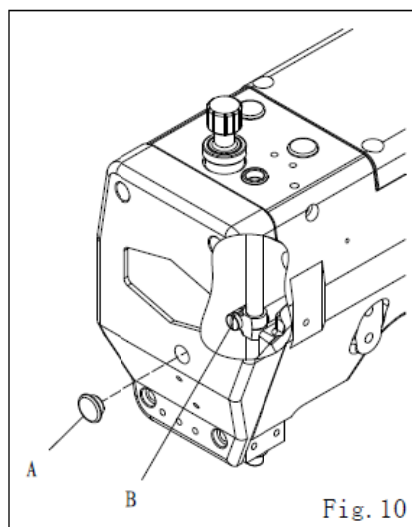
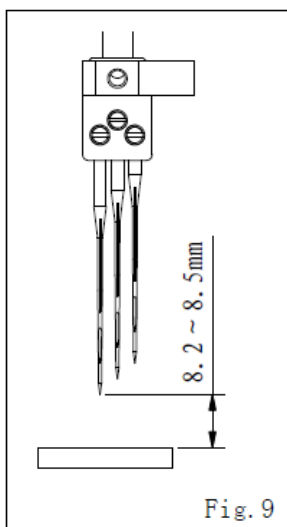



SHING RAY®

B 针与勾针之时位关系:

当勾针由右始点往左移至左针左侧, 勾针尖与针孔之距离和勾针由左始点往右回移左针右侧时, 勾针尖与针孔之距离(图 12)所示

注:

左针 (A) 之针孔至勾针尖的距离约为 1~1.2mm, 右针 (C) 针孔与下勾针孔, 需孔对孔对正。

B. THE TIMING OF NEEDLE AND LOOPER:

When Looper move to the left from right starting point and return back to the right from left starting point. The intersection point clearance (Fig.12) between looper tip and needle hole shall be exact same.

Remarks:

The clearance between needle hole of left needle(A) and looper tip is 1mm~1.2mm. The needle hole of right needle (C) has to on positive with looper thread hole.

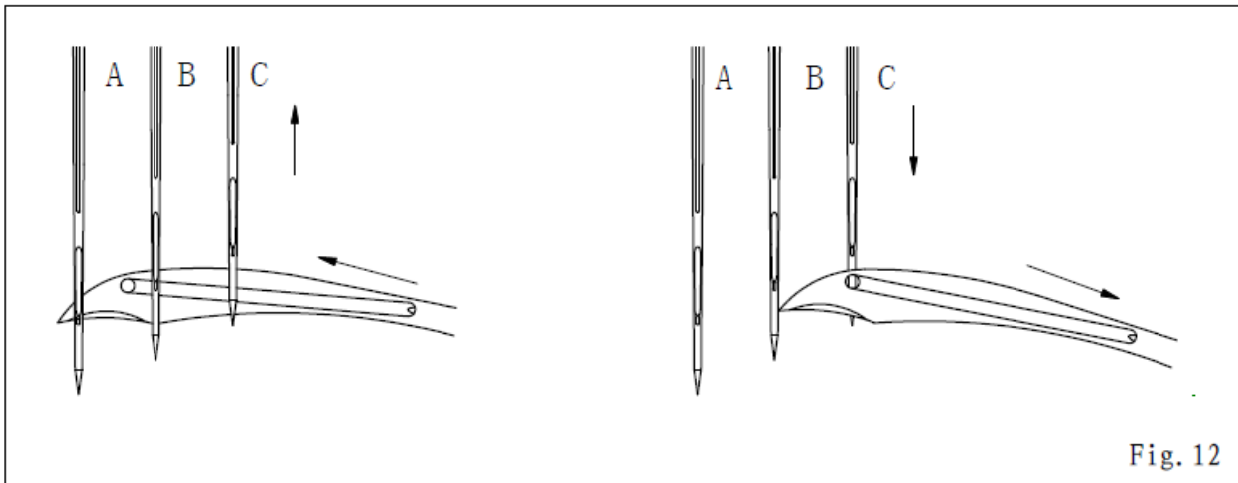



SHING RAY®

C 下勾针与针之引量:

1. 当针棒降至最低点及下勾针退至右定点时, 右针之中心点与下勾针尖之距离为 3.0~3.2mm。
2. 松开勾针座上的螺丝 (F), 调整下勾针与右针的正确距离 (图 13)。

C. THE POSITION OF NEEDLE AND LOOPER:

1. When the Needle Bar lower to the lowest position and Loper reverse to right dead point, the distance between the center of right needle to the tip of Loper is 3.0~3.2mm.
2. Loosen the screw (F) on the Loper Holder to adjust the correctly distance of Loper and right needle. (Fig.13)

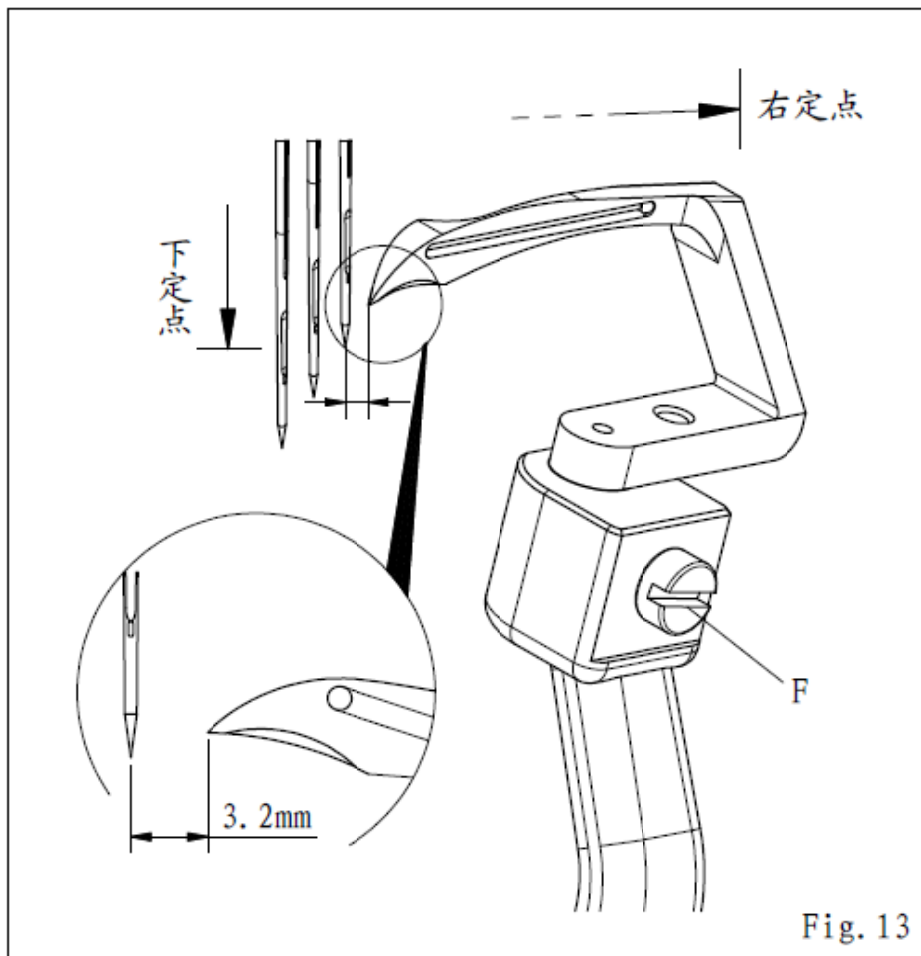

Fig. 13



SHING RAY®

D 勾针与针之间隙关系:

勾针由右往左移至右针时, 其间隙为 0mm, 至中针时为 0.1~0.2mm, 再往左移至左针时, 其间隙为 0.2~0.3mm(图 14)。

注意:

勾针前后运动之轨迹为正椭圆。

D. THE TIMING OF NEEDLE AND LOOPER:

When Looper moves to the left and meet the right needle, the clearance is 0mm. When the Looper pass the center needle, the clearance is 0.1~0.2mm. When the Looper move to left needle, the clearance is 0.2~0.3mm. (Fig. 14)

Remark:

The track of Looper pitching motion is a correct ellipse.

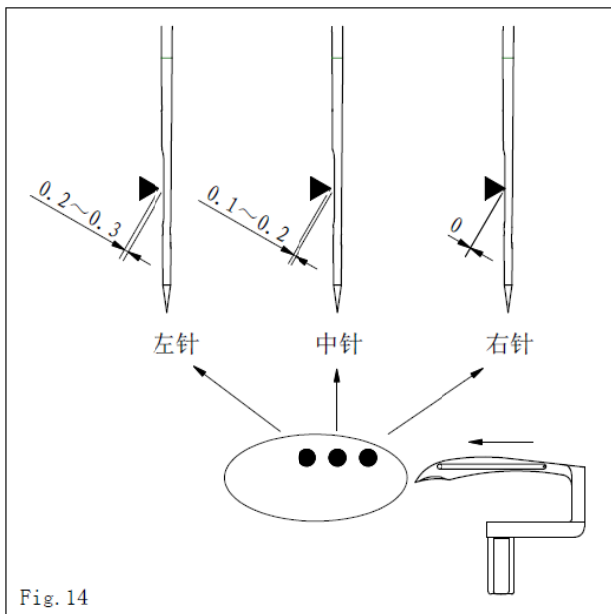



SHING RAY®

E 针与后护针片调整:

1. 当后护针片往前移出至停止不动时, 后护针片之(G)线约在右针之针眼下缘位置(图15)。
2. 勾针尖端前移至右针中心时, 后针片往前移, 与右针间隙为 $0\sim 0.05\text{mm}$, 与左针间隙为 $0.1\sim 0.2\text{mm}$ 。(图14、15)

E. ADJUSTING NEEDLE AND REAR NEEDLE GUARD:

1. When the Needle Guard moves to the front fixed point, the line (G) of Rear Needle Guard should be at the bottom of right needle hole. (Fig.15)
2. When the tip of Loper moves to the center of right needle and the Rear Needle Guard to the front side, The clearance between right needle is $0\sim 0.05\text{mm}$ and between left needle is $0.1\sim 0.2\text{mm}$ (Fig.14, 15)

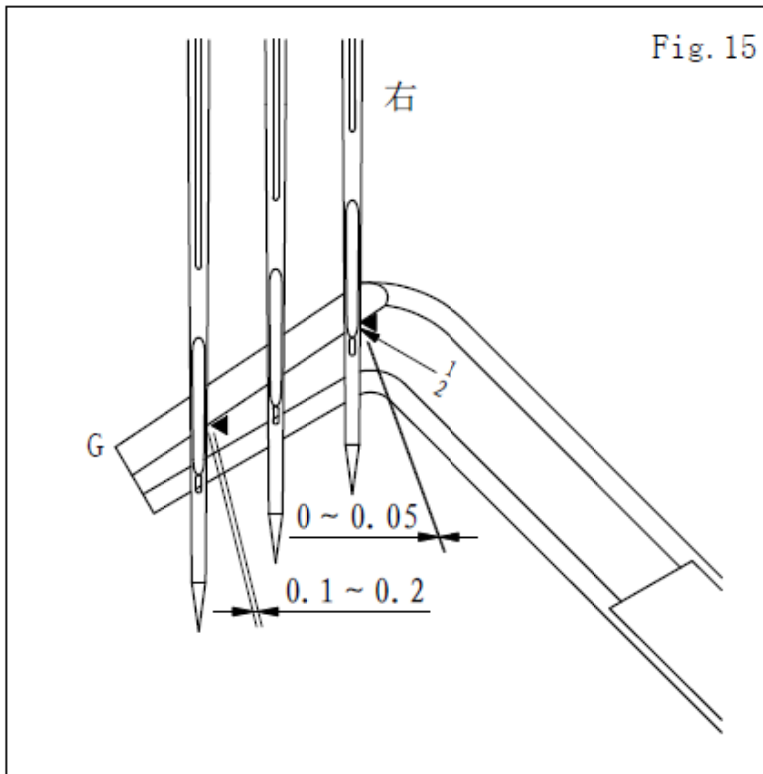



SHING RAY®

F 针与前护针片调整:

1. 当勾针之尖端移到左针中心线时, 左针尖与前护针片之(G)线约 1.5mm, 此为前护针片之高度。且左针与前护针片间隙约为 0.3mm。(图 16)
2. 当勾针退到右针中心的位置时, 右针与前护针片之距离亦为 0.3mm。(图 16)
3. 前护针片调整好时, 为平行状态。

F. ADJUSTING NEEDLE AND FRONT NEEDLE GUARD:

1. When the tip of Loper moves to the center of left needle, the distance of the tip of left needle pass the line (G) of Front Needle Guard is about 1.5mm. This is the height of Front Needle Guard. The clearance between the Front Needle Guard and right needle is about 0.3mm. (Fig.16)
2. When the Loper reverse to center of right needle, the clearance between right needle and Front Needle Guard is 0.3mm. (Fig.16)
3. When the situation of Front Needle Guard set in parallel up which meaning position is correctly.

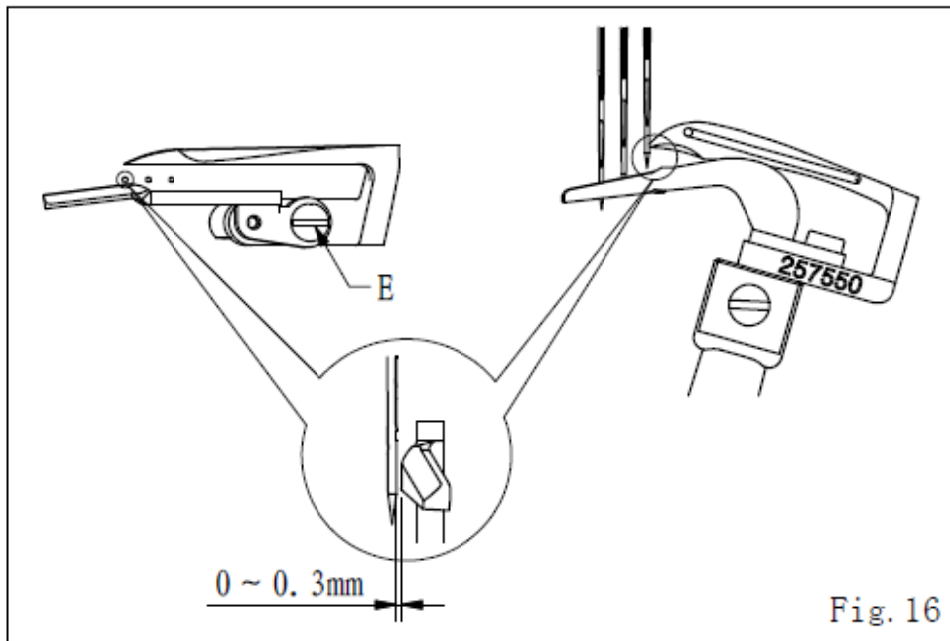



G 针与上勾针及导线片之关系:

1. 当针棒于上定位时，上勾针(A)之底部高于左针之针尖约 1mm，此为上勾针之高度 (图 18)。
2. 当上勾针由右往左边移时，上勾针之勾线尖端与左针之间隙为 0.3~0.5mm，当上勾针继续移至最左时，上勾针之勾线尖端与左针中心距离为 4.5~5.5mm。(图 19)
3. 当针棒移至最低点时，上叉导板 2 之线沟刚好在导片 3 孔之下方。且上叉导板 2 与上叉 1 之间隙为 0.5mm。导线片 3 与上导板 2 之间 1.0mm，且线孔与线沟必须相对。(图 20)

G. THE RELATIVE POSITION OF NEEDLE, SPREADER AND SPREADER THREAD GUIDE:

1. When the needle bar is positioned on the top , the bottom of the spreader is about 1mm higher than the tip of the left needle ,and this is the height of the spreader. (Fig.18)
2. When the spreader moves from right to left, the gap between the left needle and the tip of the spreader is 0.3~0.5mm. when the spreader continues to move to the left most point, the distance between the tip of the spreader and the center of the left needle is 4.5~5.5mm. (Fig.19)
3. When the needle bar moves to the lowest point, the line of the upper guide plate 2 is full just below the hole of the guide plate 3. And the gap between the upper guide plate 2 and the plate 1 is 0.5mm, and the gap between the guide plate 3 and the upper guide plate 2 is 1mm. the thread hole and grooves must be relative. (Fig.20)

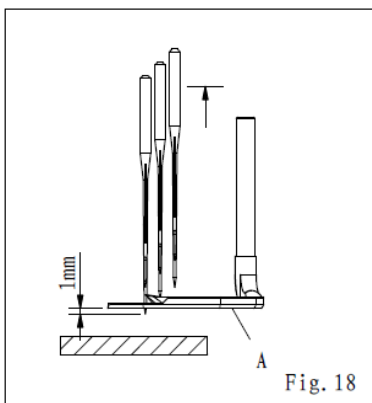

Fig. 18

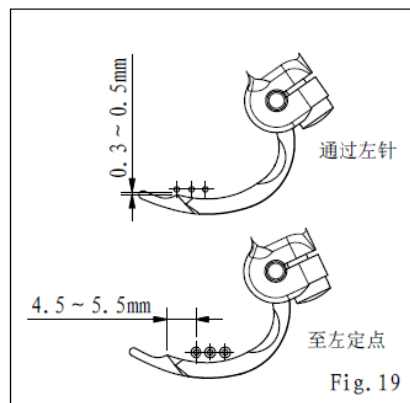

Fig. 19

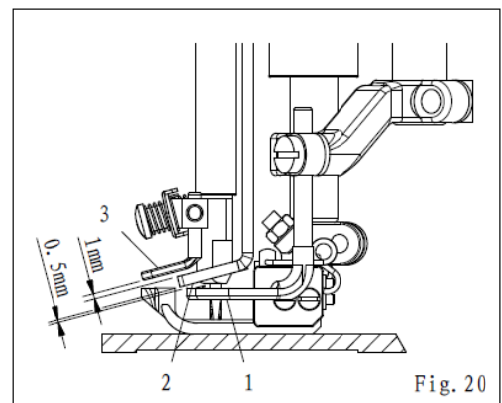

Fig. 20



SHING RAY®

H 送布齿高度调整:

送布齿在最高位置时，送布齿齿尖面与针板面平行，且此时主送布齿A与差动送布齿B，高度相同，且齿面高出针板面 1.0~1.2mm。(图 21)

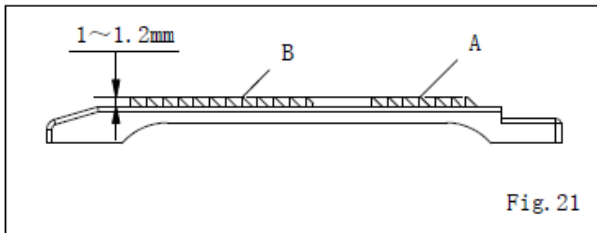

H. ADJUST THE HEIGHT OF FEED DOG:

When the Feed Dog rise up to the highest position, the surface of Feed Dog and Needle Plate must be in parallel. Besides, the teeth of Main and Differential Feed Dog must be aligned. The standard height of Feed Dog is about 1.0~1.2mm from its top teeth to Needle Plate. (Fig. 21)

I 勾针控线凸轮之调整:

1. 当针从最高点下降时，左针大约位于勾针后面之半的位置时(图 22)，勾针线必须脱离凸轮 P 之最高位置。
2. 须调整凸轮时，放松 2 个螺丝 1 调整之。

I. THE ADJUSTMENT OF LOOPER THREAD TAKE-UP:

1. When Needle comes down from the highest position, and the left Needle reaches around 1/2 position of the Loper. (Fig. 22), The looper thread will come over the highest position of Thread Cam P.
2. Loosen the two screws 1 for above adjustment.

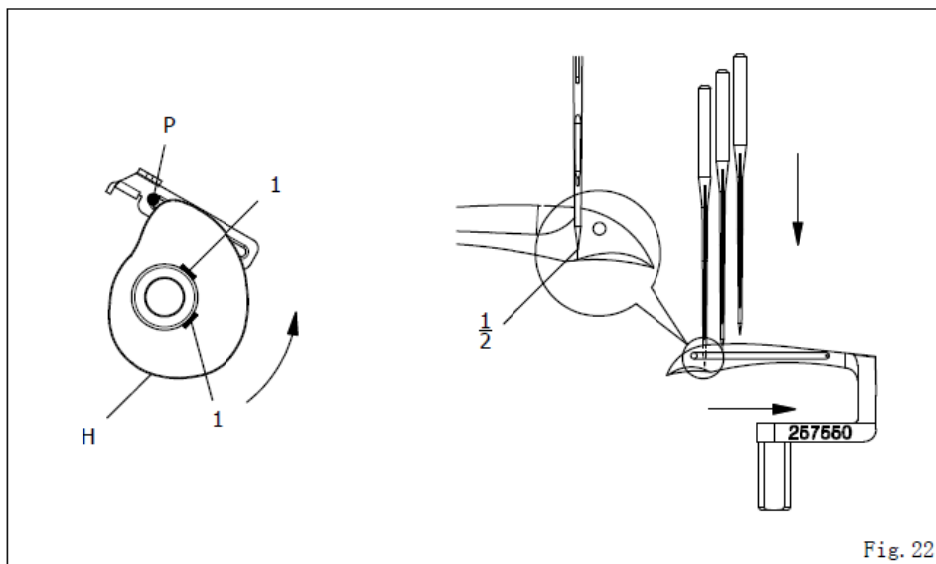



SHING RAY®

J 差动比调整:

1. 先将螺母 (B) 松开, 将 (A) 向下转动, 则差动比变大, 缝纫的布料会缩起来, 将 (A) 向下转动, 则差动比变小, 缝纫的布料伸长。
(图 23)

2. 调节玩后, 请将螺母 (B) 拧紧。
(图 23)

J. Adjusting the differential feed ratio :

1. Loosen nut (B) for the differential feed ratio adjustment.

To increase the differential feed ratio, lower lever (A).

The finished fabric is shrunk.

To decrease the differential feed ratio, raise lever (A).

The finished fabric is stretched. (Fig. 23)

2. After this adjustment tighten nut (B).
(Fig. 23)

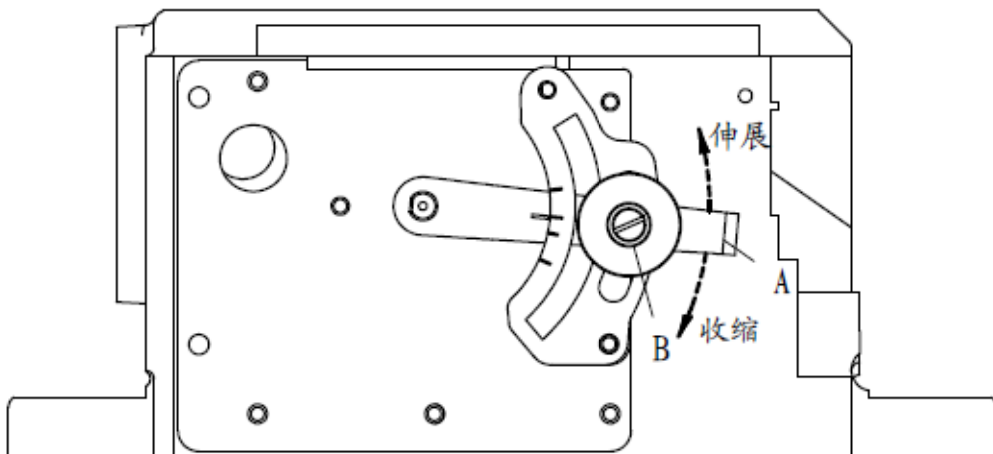

Fig. 23



自动切线调整说明

A 下切刀组相关位置调整:

注意:

下切刀组安装于机器前须先检查切刀组之相关位置和滑顺度及切线效果。

1. 当活动刀片往右移时, 右边刀口之尖端(A)与固定刀之前端(B)须对齐。且活动刀移至最右点时, 左边刀口和固定刀前端的契合度为 1.0mm。调整时可放松螺丝(C)移动固定片。(图 22)
2. 夹线片(D)之边沿须与活动刀右边刀口内沿切齐, 如(E)可由螺丝(C)调整。压力片(F)前端与固定刀前端之距离约为 1mm, 调整时, 可放松螺丝(G)移动压力片(F)。(图 28)

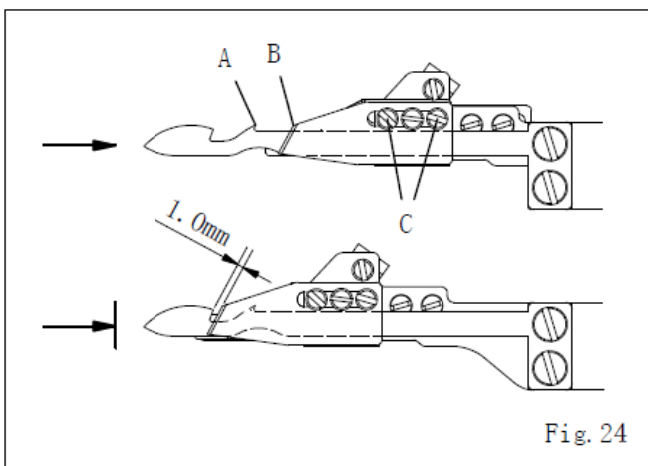

AUTO THREAD TRIMMER ADJUSTMENT GUIDE

A. THE RELATIVE POSITION ADJUSTMENT OF BOTTOM TRIMMER CUTTING PARTS:

Remark:

Before you install the new Trimmer set into machine, Please always to check the relative position, the situation of sliding and the trimming effect.

1. When Lower Moving Knife move to the right, the Moving Knife hook (A) of right hand side one align with the tip (B) of Fixing Knife. When the Lower Moving Knife move to the right dead point, The Moving Knife hook of left hand side one pass the tip of Fixing Knife in 1.0mm. Loosen the screw (C) for adjusting the position of Fixing Knife. (Fig. 27)
2. The edge of Clamp Spring (D) align with the inside edge of Moving Knife of right hand side hook (E). Please loosen the screw (C) to adjust the position of Clamp Spring and Fixing Knife. The distance between the top of Clamp Spring Pressure and top of Fixing Knife is about 1mm. Please loosen the screw (G) to adjust the position of Clamp Spring Pressure. (Fig. 28)

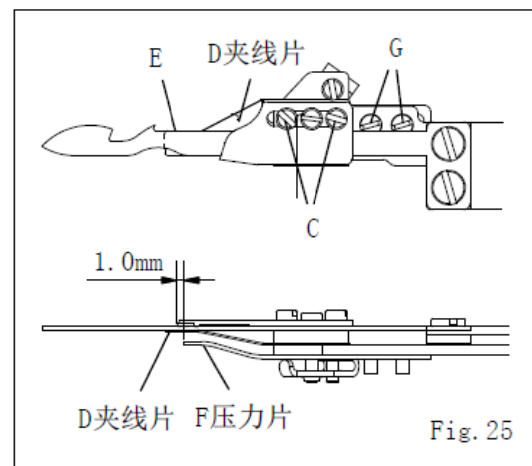



SHING RAY®

3. 夹线弹簧片的压力调整：当下勾针线被切断后，下勾针这端之线头须被夹线弹簧片与活动刀片稳定夹住。调节夹线弹簧之压力，可由螺丝(H)旋转调整。(顺时针方向压力增强，逆时针方向压力减弱)。(图 26)

3. When the looper thread has been cut off, the Clamp Spring and Moving Knife will clip the thread in stable. To increase the pressure of clipping thread turn the screw(H) clockwise and decrease the pressure turn the screw(H) counterclockwise. (Fig. 26)

注意：

夹线弹簧片之压力调整须适中，压力太强会减短活动刀片之寿命，压力太弱则下勾针线头易脱落。压力之强度以能轻易切断线即可。

Remark：

The pressure of Clamp Spring must be moderate. If the pressure has been adjusted into too strong, it will decrease the life of Moving Knife. If the pressure has been adjusted into too weak, the looper thread will easy to lose from the Clamp Spring. What is moderate pressure? It is meaning that the pressure to cut the thread easily.

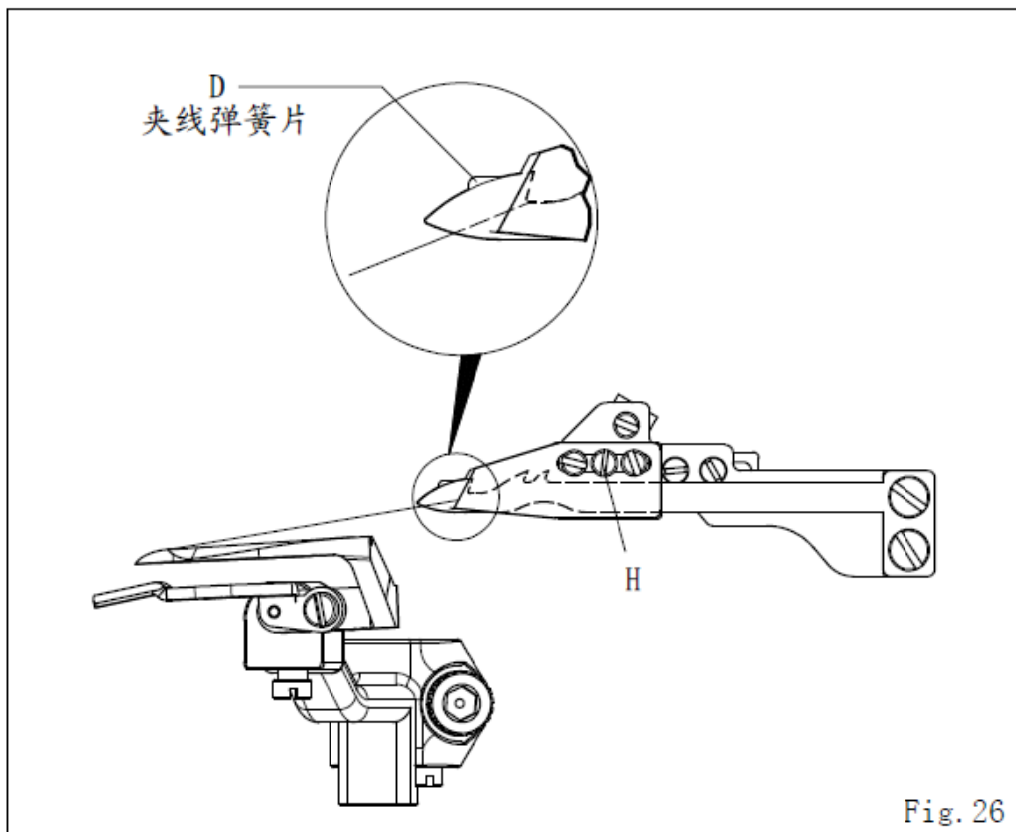



SHING RAY®

B 下切刀组、切线之相关位置：

1. 下切刀组之前后位置

当下切刀组由右定点移出至下勾针右侧时(第一段动作)活动片之刀尖(A), 约位于下勾针宽度中心, 前、后 1/2 位置(图 27)

调整时可放松摇臂之偏心轮(B)上之螺丝(C), 再转动偏心轮, 使活动刀片移到正确位置。偏心轮上之记号(D)正常时, 大约处于 3 点钟方向位置。(图 28)

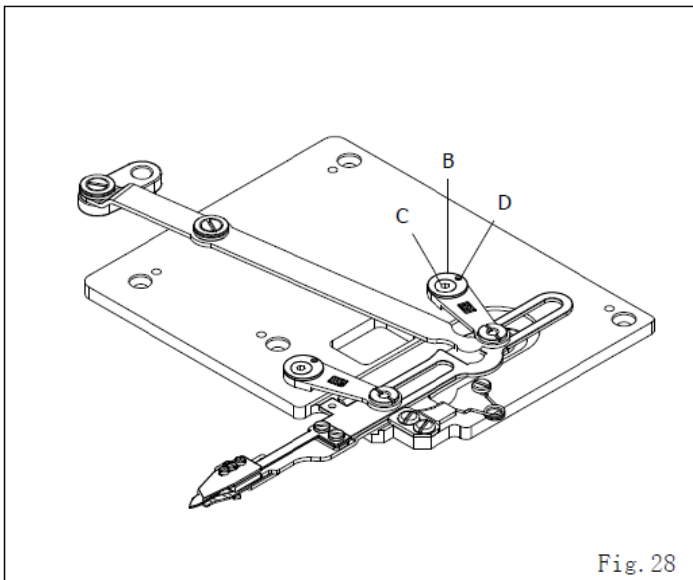

Fig. 28

B. THE RELATIVE POSITION ADJUSTMENT OF BOTTOM TRIMMER:

1. The Front and Rear position of Bottom Trimmer

When the trimmer moves out from right dead point to the right hand side of looper, (1st action) the tip of Moving Knife (A) aim to the center of looper ridge. (Fig. 27)

Please loose the screw (C) of Knife Guide Lever Eccentric Ring (B) and turn the Eccentric Ring for regulating the Moving Knife into right position.

Please set up the mark (D) of Eccentric Ring to 3 o'clock position in ordinary. (Fig. 28)

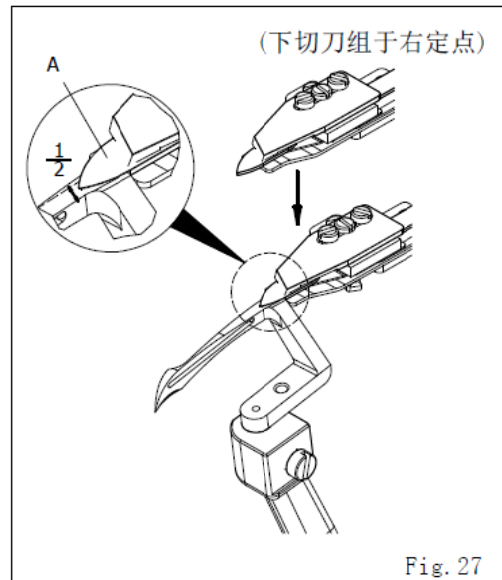

Fig. 27



SHING RAY®

2. 下切刀组之左右位置一

当下切刀组之活动刀片(A)往左移至左定点时，活动刀(A)之刀尖，须超出下勾针(B)之左边穿线孔约1mm。(图29)

调整时，可放松连结滑块(C)上的螺丝(D)，再用螺丝刀旋转螺丝(E)，微调活动刀片左右位置至正确点后，再锁紧螺丝(D)。(图30)

注意：

1. 下切刀组完成调整时，须再次用手动移出活动刀片，确认相关位置是否正确、顺畅。
2. 当必须调整下切刀组相关位置时，须确认针棒是否处于上定点，下勾针位于左定点(此为切线点)。

2. The Right and left position of Bottom Trimmer-

When the Moving Knife move to the left dead point, the tip of Moving Knife has passed 1mm over than the threading hole of looper. (Fig. 29)

When you would like to adjust the right & left position of Moving Knife. First, please loose the screw (D) of Connecting Block (C), to turn the screw (E) by screwdriver for micro adjusting the correct right & left position of Moving Knife., then to locked the screw (D) down. (Fig. 30)

Remark:

- (1)When you finish adjusted, please be moved the Bottom Trimmer by hand to confirm the relative position correctly & smoothly.
- (2)When you adjust the relative position of Bottom Trimmer, please always confirm the needle bar in the top dead point & the looper in the left dead point which are the timing of cutting thread.

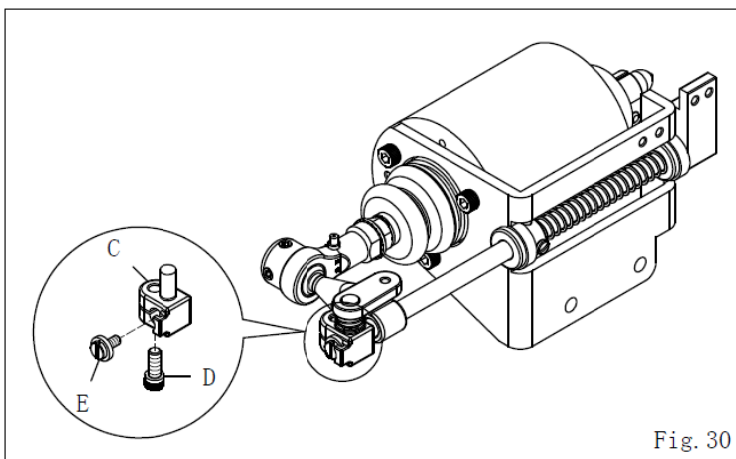

Fig. 30

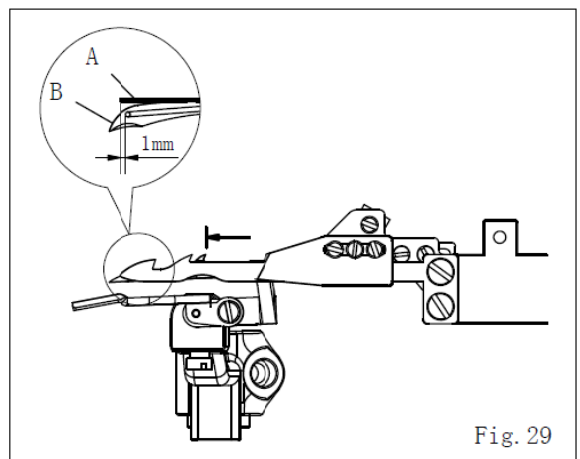

Fig. 29



SHING RAY®

C 下切刀组与针线及下勾针线之关系:

1. 当活动刀片 (A) 往左边移时, 必须通过针线之线环 (B)。(图 31-1)
2. 当活动刀片往左移至左定点时, 下勾针线 (C) 须滑入活动刀片 (A) 之左边刀口 (D) 内。(图 31-2)
3. 活动刀片往右回移时, 活动刀片右刀口须勾住针线, 左刀口勾住下勾针线, 一起往右拉回。(图 31-3)
4. 针线及下勾针线由活动刀片拉回与固定刀切断, 针线切断后自然脱落, 下勾针线靠下勾针一端线头须稳稳夹住于切刀。(图 31-4)

C. THE RELATIVE POSITION OF NEEDLE, LOOPER THREAD AND BOTTOM TRIMMER:

1. When the Moving Knife (A) move to the left which must be passed the loop (B) of needle thread. (Fig 31-1)
2. When the Moving Knife move to the left dead point which looper thread must be dropped into the left hook (D) of Moving Knife (A). (Fig. 31-2)
3. When the Moving Knife move to the right, the right hook of Moving Knife must hooks the needle thread and left hook must hooks the looper thread to pull into right side in same time. (Fig.31-3)
4. The needle & looper thread are pulled back by Moving Knife and be cut by Fixing Knife. The needle thread must be cut in efficiently and looper thread has clipped by Bottom Trimmer in stably. (Fig. 31-4)

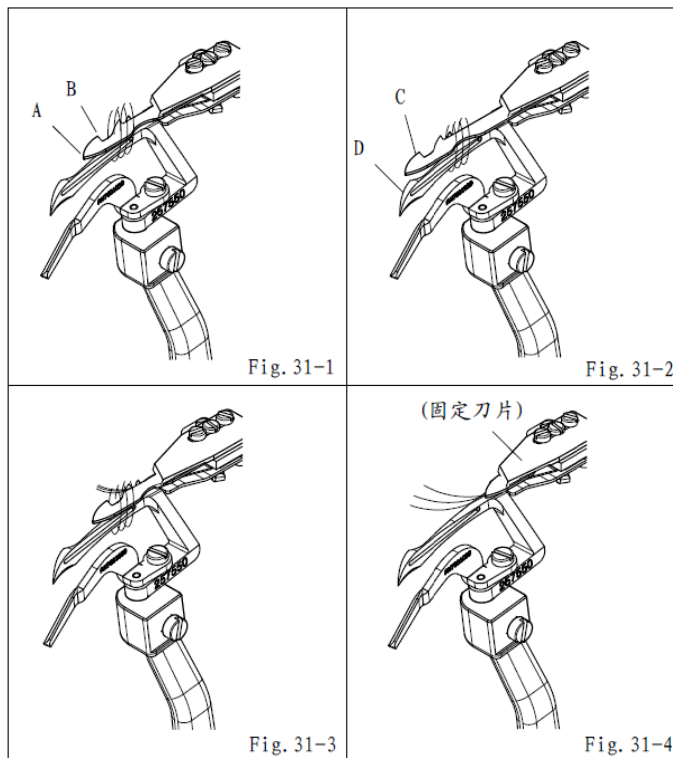



SHING RAY®

D 上切刀组与上饰线、针及勾针之关系:

注:

安装调整上切刀组前,必须先确认针棒是否停于上定点,且上勾针之相关位置必须处于正常状态下。

1. 上切刀组高度调整:

当活动刀片(A)移至最低点时活动刀之刀尖与上勾针(B)之上沿须切齐等高(C)。(图32)调整时放松上切刀组(D)上之两个螺丝(E),再上下移动上切刀组之位置。(图33)

2. 上切刀组之刀片压力调整:

上切刀组之活动刀与固定刀压力可由螺丝(F)旋转微调至适当压力。(图33)

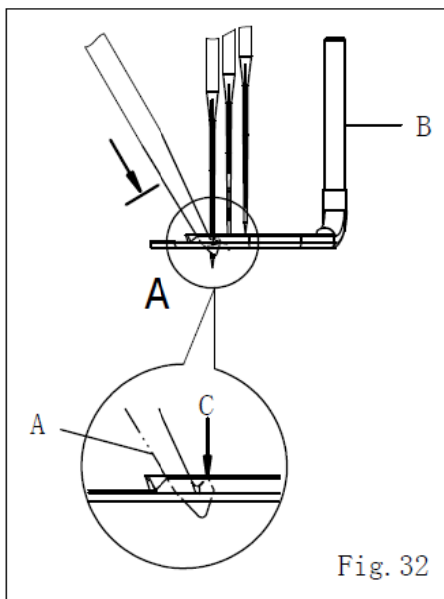

Fig. 32

D. THE RELATIVE POSITION OF SPREADER THREAD, NEEDLE, SPREADER AND TOP TRIMMER:

Remark:

before installing and adjusting the Top Trimmer C.Set, It's necessary to confirm whether the needle Bar at the upper fixed point, and the relevant position of the spreader needle must be in the normal state.

1. The height adjustment of Top Trimmer:

When the Top Trimmer Moving Knife move to the lowest point, the tip (C) of Moving Knife align with top of Spreader (B). (Fig. 32)

To loose the two screws (E) of Top Trimmer (D) then, to adjust up and down for top trimmer position. (Fig. 33)

2. The pressure adjustment of Top Trimmer:

The pressure of Top Trimmer Moving & Fixing Knife which be adjusted via micro turn the screw (F) to get the suitable pressure. (Fig. 33)

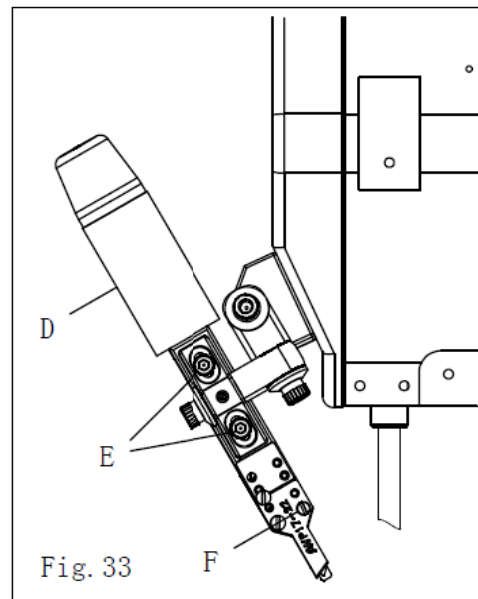

Fig. 33



SHING RAY®

3. 上切刀组角度之调整:

注:

调整上切刀组角度前, 须先调好上切刀组之高度。

当活动刀片(A)往下移至下定点时, 活动刀片(A)须位于针及上勾针(B)之间隙中央, 特别注意不可和针磨擦碰撞(图 34)。且活动刀片(A)往下移时, 刀片前端斜面须和上饰线有磨擦接触情形(C) (图 35), 当活动刀片往上收刀时, 上饰线才能顺利滑入刀槽内。

调整上述关系位置时, 可放松上切刀组(D)之固定座上螺丝(E)、(F)、(G)调整。(图 36)

三个螺丝放松顺序为(E)→(F)→(G); 锁紧时则反向顺序为(G)→(F)→(E)。

3. The angle adjustment of Top Trimmer:

Remark:

Before to adjust the angle of Top Trimmer, please make sure the height of Top Trimmer is correctly.

When the Top Trimmer Moving Knife (A) move to the lowest point, the Moving Knife (A) must be located in the center of needle and spreader(B). We would like to special mention that the Moving Knife don't touch and collide the needle(Fig.34). When the Moving Knife moves down, the top bevel of Moving Knife must be touch the spreader thread (C) (Fig.35), which will cause the spreader thread drop into the hook of Top Trimmer Moving Knife.

To adjust the above relative position, please loose three screws (E), (F), (G) of Top Trimmer Fixed Block for adjusting. (Fig.36)

To lose the three screws step is (E)-(F)-(G) and lock down step is (G)-(F)-(E).

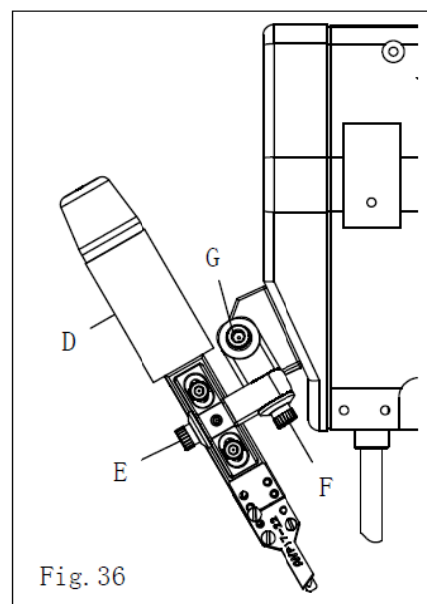
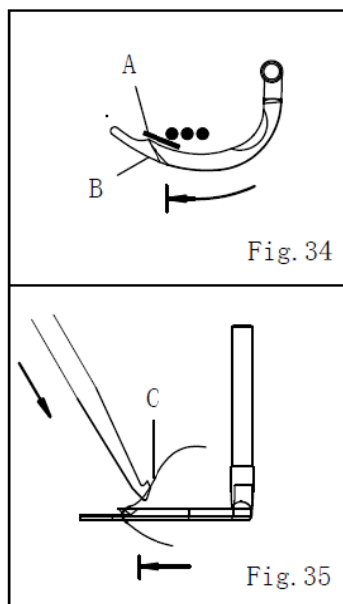



SHING RAY®

E 拨线器相关位置调整:

1. 拨线器(A)之高度:

当拨线片(B)往下摆动至呈水平状态时, 拨线片底部与左针之针尖正好切齐, 此为拨线器之高度。(图 37)

2. 拨线片(B)之前后位置:

当拨线片(B)通过押脚时, 拨线片与押脚前沿之间隙为1mm。(图 37)

3. 拨线片(B)之左右位置:

当拨线片(B)移到左定点时, 拨线片之勾线尖端与左针之距离约为3.5mm。(图 38)

注:

调整时, 可放松两个螺丝(C), 调整拨线器(A)之相关位置。(图 39)

E. THE RELATIVE POSITION OF TOP WIPER:

1. The height of Top Wiper (A):

When the Wiper (B) swings to the bottom in level, the bottom of Wiper align with the tip of left needle which is the height of Top Wiper. (Fig.37)

2. The front & rear position of Wiper (B):

When the Wiper (B) passed the Presser Foot, the clearance between the Wiper and Presser Foot is 1mm. (Fig.37)

3. The right & left position of Wiper (B):

When the Wiper (B) swings to the left dead point, the clearance between the hook tip of Wiper and left needle is 3.5mm. (Fig.38)

Remarks:

To lose the two screws (C) for adjusting the relative position of Top Wiper (A). (Fig.39)

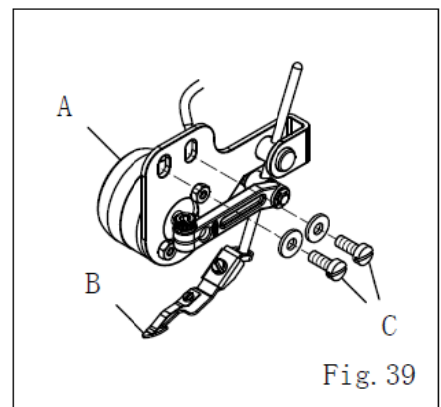
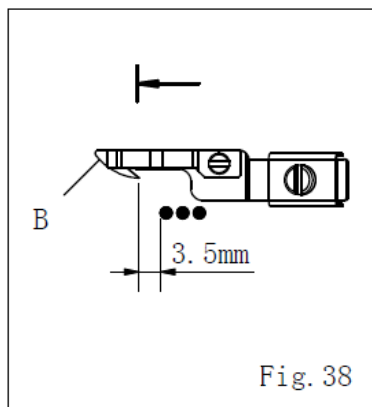
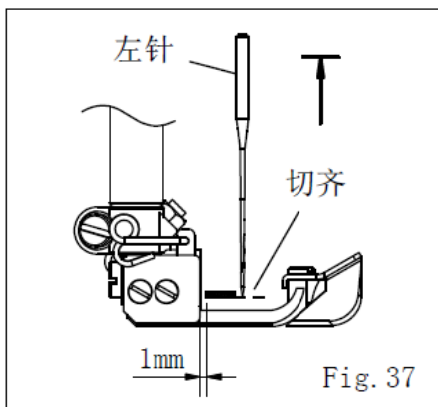



SHING RAY®

简易故障排除

A 清洁保养:

1. 机器外表须经常保持干净避免棉屑阻塞过线孔及夹线片,造成线迹不顺。
在清洗缝纫机时,务必将缝纫机电源关闭,将插头从电源插销上拔下来之后再行进行。
2. 打开前护盖(C)、(B),请松开螺丝(E),卸下针板(D)。(图40)
3. 请打扫针板(B)的空槽和送布齿(C)周围。(图40)
4. 请用螺丝(E)安装针板(D),并且关闭前护盖(C)和插座(B)。(图40)

REGULAR MAINTENANCE:

A. THE CLEAR AND MAINTENANCE:

1. Please always clean the machine appearance to avoid the cotton waste obstructs the threading hole and thread clamp which to cause the stitch unstable.
Always turn off the power and unplug the machine when you clean the machine.
2. Open from cover(C) and slide plate(B). Loosen screws(E) and remove needle plate(D). (Fig. 40)
3. Clean the grooves(B) of the needle plate(D). (Fig. 40)
4. Replace needle plate(E) with screws(D). Then close from cover(C) and slide plate(B). (Fig. 40)

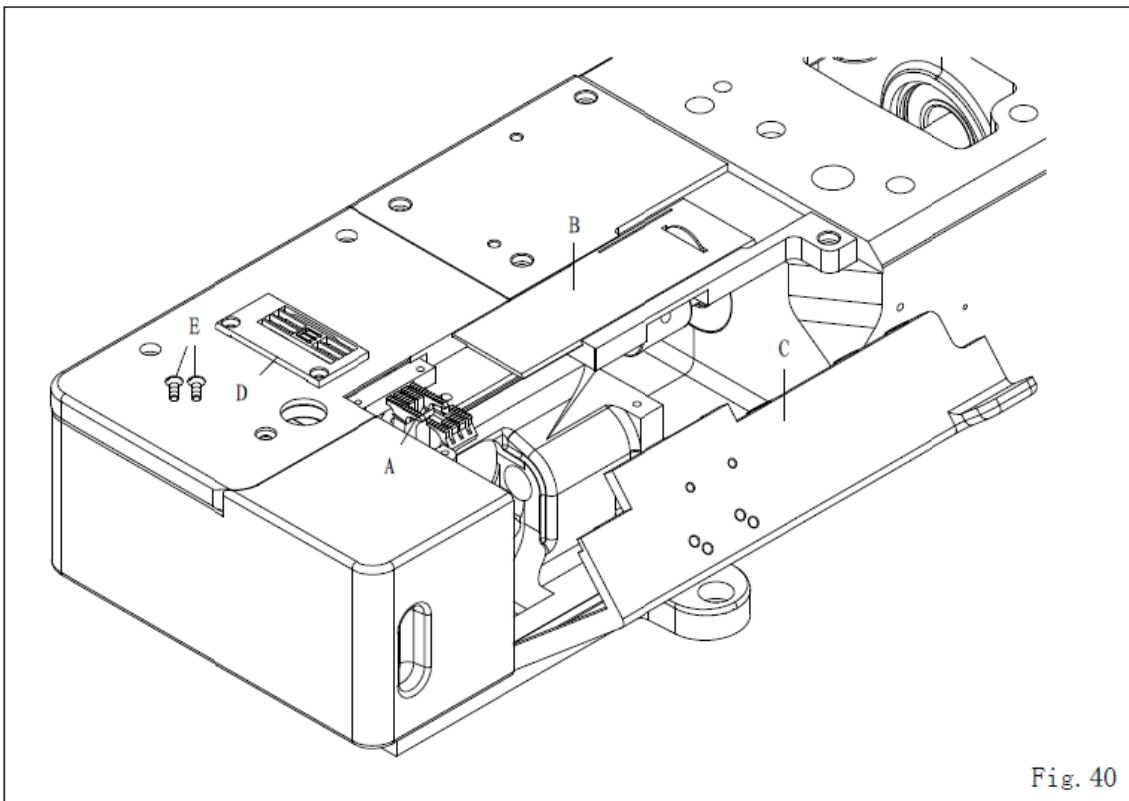



SHING RAY®

B 故障（用户）自主检查：

状况 1：跳针、断线
排除：

1. 是否使用错误型号之机针。
2. 使用机针是否已弯曲，毛边或未装至定位或未装正。
3. 车缝线是否存放过久或线本身粗细不均，接头太多或有漏穿线情形。
4. 注意针线及底线（下勾针线）之控线沙拉组是否太紧或太松。
5. 底线（下勾针线）之控线凸轮时位关系，检查是否已走位。（此项须由技术人员检查调整）
6. 检查前后护针片之相关位置是否正确。（此项须由技术人员检查调整）
7. 下勾针尖是否已毛边磨损，或下勾针与针之时位关系已被调整走位。（此项须由技术人员检查调整）

状况 2：车缝不顺产生布料波浪或斜纹
状况

排除：

1. 针对布料性质调整前牙差动比率：

波浪情形—前牙差动调大；

斜纹情形—前牙差动调小。

B. ERROR MESSAGES (THE USER INSPECTS THE MACHINE BY THEMSELVES) :

Status1:Skipped Stitch, Broken Thread
Solution:

- a. Do you use a wrong model needle.
- b. Does the needle bent. Does the tip of needle cracked. Or, the needle doesn't be installed in correctly position.
- c. Does the thread keep in stock too long. Does the thread's thickness uneven. Does the thread too many connectors. Or, there is lose threading some threading eyelet.
- d. Please check the tension of needle & looper thread have been adjusted too loosen or too tight by Thread Tension Adjuster.
- e. The looper thread take-up is out of timing. (Please ask the machinist to check and adjust it)
- f. Please check the relative position of Front & Rear Needle Guard are correctly. (Please ask the machinist to check and adjust it)
- g. Please check the tip of looper have cracked or wore. The timing of looper and needle is out of order. (Please ask the machinist to check and adjust it)

Status2:The Unstable Sewing engender Puckering and the folding parts didn't be seamed in even

Solution:

- a. To refer the nature of fabric for adjusting the differential feed dog. Differential Rate:
Puckering—To adjust the differential feed dog ratio in large.
The folding parts didn't be seamed in even—To adjust the differential feed dog ratio in small.



SHING RAY®

2. 注意押脚压力须适中,且不能与针板面有间隙。
3. 送布牙须视车缝布料之厚薄、伸缩性质,调整适当高度。
4. 车缝人员控制衣物之手势、力道,须视布料性质不同做配合。

状况 3: 机器产生异音情形排除:

1. 检查机头与桌板之固定螺丝、垫片、防振塑料等之安装方式是否未依安装说明安装,而产生桌板共振之异音。(以直驱式小马达机器为主)
2. 检查机器前盖、面盖螺丝是否有松脱或有因拆装后未密合即再锁紧,而产生的异音。
3. 检查油量是否太少,造成机器润滑不够、发烫产生之异音。

状况 4: 不喷油或不吸油情形

排除:

1. 检查喷油管及吸油管是否有破裂或接头未锁紧而有漏气情形。

- b. The pressure of presser foot must be moderately. Please take care that the needle plate between presser foot didn't have any gap.
- c. The height of feed dog must be refer to the nature of fabric for adjusting a reasonable height.
- d. The operator is according to the nature of fabric for adjusting the holding way of sewing and the tension of fabric be seamed.

Status3: The machine noise in operation

Solution:

- a. Please always follow the installation to fix the machine head and table. The wrong installation will engender the noise which come from the machine head and table resonance. (Main item: D.D. Type Mini Servo Motor)
- b. Please check the front cover and screws. If the noise come from the loosen screw or front cover, please screw and fix them again.
- c. Please check the lubrication oil is enough or not? If the lubrication oil isn't enough which will to cause the machine noise and heat.

Status4: The lubrication system don't spout out the oil or inhale the oil back

Solution:

- a. Please check the oil tube have broken or not? Does the connector be locked well? If the oil tube had broken, please change it. If the connector didn't lock well, please lock it well.



SHING RAY®

2. 送布牙架下方之吸油管及针棒内侧之吸油管、如有积油情形时须检查是否因棉屑累积太多未清除造成吸油管阻塞。

3. 检查吸油管与吸油海棉是否正常接触。

状况 5: 针线或底线切不断情形

排除:

1. 切线点不对，机器停的时候针棒是否未停在上死点。
2. 下切刀之活动刀片，前进至左定点时，行程是否不够。
3. 下切刀组向左前方移出时(第一段动作)刀尖之前后位置是否不正确。
4. 刀片弹簧压力是否调得太弱。
5. 检查活动刀，固定刀是否有磨损或相关位置有异位。
6. 电压过低造成传动之电磁阀力道变弱。
7. 针板下方棉屑是否积存太多而影响活动刀无法准确进入线圈。

状况 6: 上饰线(网线)切大断情形

排除:

1. 依照上切刀之调整说明，检查活动刀片剪线之相关位置是否正确。

b. If there are a lot of oil in the bottom of cylinder- bed or the bottom of needle bar, please check these two places have accumulated a lot of cotton waste to block the Inhale Oil Tube or not? "Please always clear the cotton waste at least two times per week.

c. Please check the Inhale Oil Tube have connecwith Inhale Felt in correctly place.

Status5: The "Bottom Trimmer" can't cut the needle & looper thread out
Solution:

- a. The point of trimming is incorrect. The needle bar didn't stop at top dead point when the machine stop.
- b. The moving knife of bottom trimmer move to the left dead point which the moving stroke isn't enough.
- c. In 1st motion of Bottom Thread Trimmer, the tip of moving knife which position is correctly or not?
- d. Is the pressure of clamp spring too weak?
- e. Please check the moving & fixing knife have abraded or relative position is out of order.
- f. As the voltage drop, to cause the power of solenoid for trimmer is going to weak.
- g. There is too much cotton waste to accumulate under the needle plate which impede the moving knife didn't enter the thread hole in precisely.

Status6: The "Top Trimmer" can't cut the spreader thread out
Solution:

- a. Please follow the installation manual of top trimmer to check all of top trimmer relative position is correctly or not.



SHING RAY®

2. 检查上切刀上之弹簧压力是否太弱。
3. 检查上勾针之相关位置及行程是否正确。

状况 7：拨线器无法将针线头拨起时

排除：

1. 先试缝确认每次切线时，针线是否每次都有被下切刀完全切断；因针线未被下切刀切断时，拨线器则无法顺利将线头拨离针板面。
2. 检查拨线器，安装之位置是否有依前述说明正确安装。
3. 检查拨线器，回归时弹力是否异常太弱，有活动不良的情形。

注：

如是针线未被切断导致拨线器无法将线头拉出而卡在针下方时，必须先用剪刀剪断针线，使拨线器之拨线勾针能回归原点，否则会造成针与拨线勾针相互碰撞的情形。

- b. Please check the pressure of top trimmer clamp spring is too weak or not?
- c. Please check the relative position & stroke of spreader is correctly or not?

Status7: The thread wiper can't take the needle thread up

Solution:

- a. Please double confirm the bottom trimmer have always cut the needle thread. If the needle thread didn't be cut out, the wiper is impossible to take the needle thread up.
- b. Please check the position of thread wiper have followed the installation manual to set up in correctly.
- c. Please check the return elasticity of top wiper is too weak, or the wiper didn't move smoothly.

Remark:

If the needle thread didn't be cut by trimmer which will cause the "Top Wiper" can't take the needle thread up. Please use the thread clipper to cut the needle thread which didn't be cut by under trimmer. To let the "Top Wiper" return back to the initial place which to avoid the hook of wiper crash the needle.



SHING RAY®

状况 8：前踩踏板、机器不能运转时

排除：

1. 检查保护下切刀组回归定位之安全开关小绿灯是否亮着(位于机头后方，安全开关上)。如未亮则表示下切刀组未回归定位，安全开关自动断电以保护下切刀不被碰撞。
2. 检查计算机控制箱显示之代号，再对照马达说明书之故障代号说明，排除问题。
3. 检查机头马达与电脑控制箱之中继线、插头是否有松脱或未插紧，而造成接触不良的情形。

状况 9：后踩踏板时，切刀组及自动抬脚全无动作之情形

排除：

1. 检查机头后方之连接端子上电线是否脱落，造成各活动部位(下切刀、上切刀、抬脚)未接收到讯号，而无法动作。
2. 用手动方式检查切刀机构及松紧机构是否顺畅无卡死情形。

Status8 : To step on the pedal in the front which the machine didn't operate

Solution :

- a. Please check the green light on the Under Trimmer Position Security Switch is be switched on or off. (The green light locate at back side of machine head) If the green light is be switch off which meaning is that under thread trimmer
- b. Please check the error code which be showed on the screen of control box. then, to follow instruction manual for solving the problem.
- c. Please check the plug of junction line which between the servo motor and control box. Have the plug been plugged in well? Or, the plug has plugged too loose which to cause the bad connection.

Status9 : To step on the pedal in rear which the Thread Trimmer System and Pressure Foot Lifter didn't operate

Solution:

- a. Please check the terminal of Top, Bottom Thread Trimmer and Pressure Foot Lifter junction line for which locate at backside of machine head. If the terminal didn't connect well, the signal is going to bad transmission to cause these moving parts didn't operate.
- b. Please use your hand to push the Under Thread Trimmer System and Thread Pull-Off Mechanism. Then, Please check these mechanisms move smoothly or not.



SHING RAY®

3. 检查电脑控制箱上显示代号，对照说明书上显示之代号，对照说明书上之异常状况为何。

c. Please check the error code which be showed on the screen of control box. then, to follow instruction manual for solving the problem.

C 调整基准数值表:

调整基准数值

FW-760	X□□□□														
										240	9.3	4.0~4.3	8.3~8.7	4.5~5.5	17.0
FW-760T	240	8.5	9.3	4.0~4.3	8.3~8.7	4.5~5.5	17.0	0.8~1.2							
									356	8.5	3.2~3.5	8.3~8.7	4.5~5.0	17.0	0.8~1.2
									356	8.5	3.2~3.5	8.3~8.7	4.5~5.0	17.0	0.8~1.2
FW-760FR	356	8.5	8.5	3.2~3.5	8.3~8.7	4.5~5.0	17.0	0.8~1.2							
FW-760Q	356	8.5	8.5	3.2~3.5	8.3~8.7	4.5~5.0	17.0	0.8~1.2							

针号对照表

日本针号 (Organ)	#	9	10	11	14	16	18	21
德国针号 (Schmetz)	Nm	65	70	75	90	100	110	130

标准用针

CW562N-01GB -02GB -05CB	X□□□□	Organ UY128GAS
	232	9S
	240	9S
	348	10S
	356	10S
	364	10S



SHING RAY®

D 针距规格表:

型号	用途	针距	针距							针脚长 (mm)	针脚长 (mm)	针脚长 (mm)	针脚长 (mm)	
			2.4	3.2	4.0	4.8	5.6	6.0	6.4					
FW-760	基本缝	2		○	○				4	1.2 ~ 4.4	0.5 ~ 1.3	5	6000	
		3				○	◎		○					5
FW-760T	下摆折边用	2			○	○			4	1.2 ~ 4.4	0.5 ~ 1.3	6.3	6000	
		3					◎		○			5		5
	盖缝用	2			○	○	○		○	1.2 ~ 4.4	0.5 ~ 1.3	6.3	6000	
		3				○	◎		○			5		5
	基本缝	2		○	○				4	1.2 ~ 4.4	0.5 ~ 1.3	5	6000	
		3				○	◎		○			5		
FW-760FR	右切刀	2				○	◎		○	5	1.2 ~ 4.4	0.5 ~ 1.3	5	6000
FW-760Q	上滚边用	2	○	○	○	○	○			4	1.2 ~ 4.4	0.5 ~ 1.3	6.3	6000
		3				○	◎		○	5			5	

F 致 敬爱的用户们:

这本「操作说明书」希望能使您更了解星锐公司的产品，也能助您排除一些异常状况：如有任何无法解决或维修上的问题，非常欢迎您与我们各地区之经销、代理商联络，他们都非常乐意为您服务，谢谢大家的爱护与支持。

F. CONCLUSION:

Dear Users,
We hope this "Instruction & Maintenance Book" could offer you more information about our "Shing Ray" products and help you to solve these unusual conditions of our machine. If you have any further requested and some problems about the maintenance, we are warmly welcome you to contact with our distributor and sloe agency in your country. All of them are willing to service you. Finally, we are sincerely to thanks all of yours continuing supports.

SHING RAY[®]
INDUSTRIAL SEWING MACHINE
星锐牌工业用缝纫机

版权所有 · 翻印必究



星锐缝纫机(嘉兴)有限公司

SHING RAY SEWING MACHINE(JIAXING) CO., LTD.

※ 本书所记载的规格式样或外观，因加以改良，有时不预告即加以变更，请见谅。 The specifications in this book are subject to change without notifications.

2020.09